

Amplifier Noise

INEL 5207 - ECE Dept. UPRM

M.Toledo - Spring 2009

Objectives

- Estimate expected amount of output noise
- Determine minimum usable signal level
- Gain insight into possible improvements

Basic Concepts

- Types of noise:
 - interference, or external, noise
 - d.c. offsets are a form of noise
 - we will study **internal or inherent**

- RMS value over averaging interval T:

$$X_n = \frac{1}{T} \sqrt{\int_0^T x_n^2(t) dt}$$

- X_n^2 is the *mean square value* of noise
- x represents current i or voltage e
- We will deal with multiple sources of noise
- Different noise sources are added as vectors

$$X_n = \sqrt{X_{n1}^2 + X_{n2}^2}$$

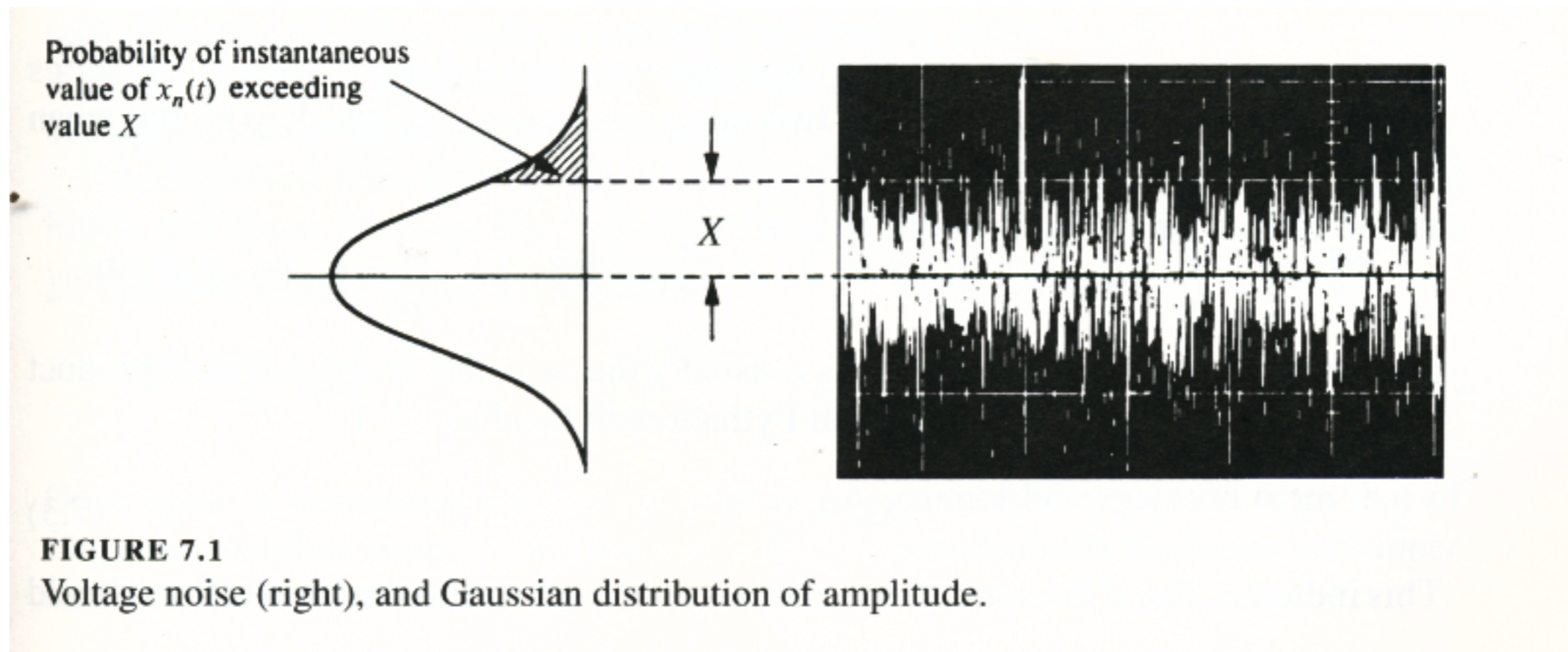

Crest Factor: ratio of noise's peak value to rms value

Cress Factor	probability
1	32%
2	4.6%
3	0.27%
3.3	0.1%

Common practice:
peak-to-peak noise value
= $6.6 \times \text{rms}$

Frequency Domain

- Noise RMS: computed in the frequency domain
- The *noise power density* (rate of change of noise power with frequency) is normally specified

$$x_n^2(f) = \frac{dX_n^2}{df}$$

- From the power density the rms value is found

$$X_n = \sqrt{\int_{f_L}^{f_H} x_n^2(f) df}$$

- replace X with I for current, V for voltage
- rms value is for a specific frequency band

White & $1/f$ Noise

➡ White: uniform spectral density

$$X_n = x_{nw} \sqrt{f_H - f_L}$$

➡ white-noise power: proportional to BW

➡ $1/f$ noise: varies with reciprocal of f

$$x_n = \frac{K}{\sqrt{f}} \rightarrow X_n = K \sqrt{\ln(f_H/f_L)}$$

➡ $1/f$ - noise power is proportional to # of decades or octaves

IC noise - mixture of white+1/f

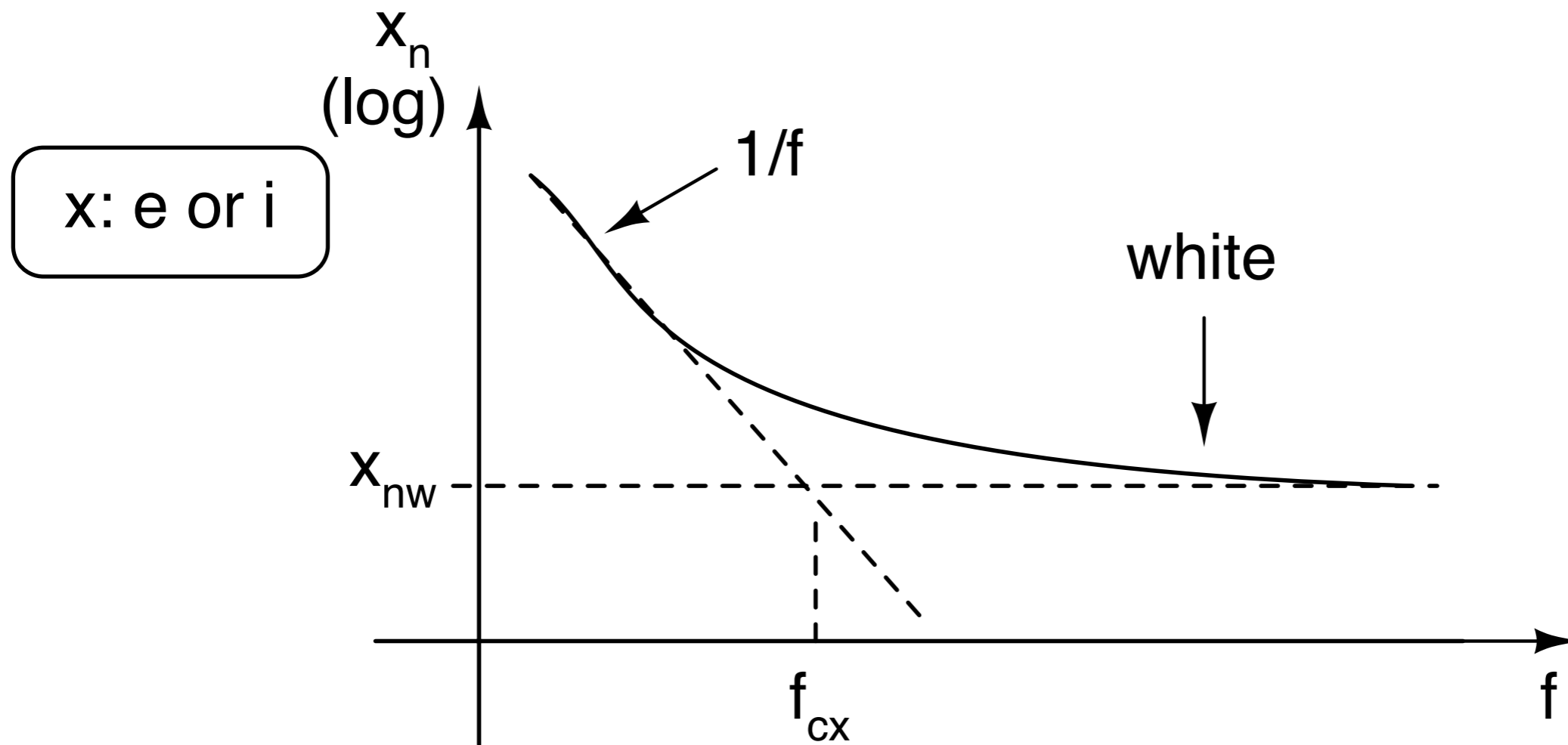

$$x_n^2 = x_{nw}^2 \left(\frac{f_{cx}}{f} + 1 \right)$$

$$X_n = x_{nw} \sqrt{f_{cx} \ln(f_H/f_L) + f_H - f_L}$$

Example: For uA741,

$$e_{nw} = 20 \text{ nV}/\sqrt{\text{Hz}}, \quad f_{ce} = 200 \text{ Hz}$$

$$i_{nw} = 0.5 \text{ pA}/\sqrt{\text{Hz}}, \quad f_{ci} = 2 \text{ kHz}$$

rms noise for audio band (20Hz to 20kHz)

$$\begin{aligned} E_n &= 20 \times 10^{-9} \sqrt{200 \ln \left(\frac{10^2}{0.1} \right) + 20000 - 20} \\ &= 2.92 \mu\text{V} \end{aligned}$$

- Normally noise is described by specifying e_{nw} and f_{ce} (voltage) or i_{nw} and f_{ci} (current)
- Source of noise appear in different places, and equivalent input noise sources are found
- Input sources are filtered by amplifier to produce output noise
- To simplify calculations, actual magnitude response is replaced by a *Brick-wall equivalent*

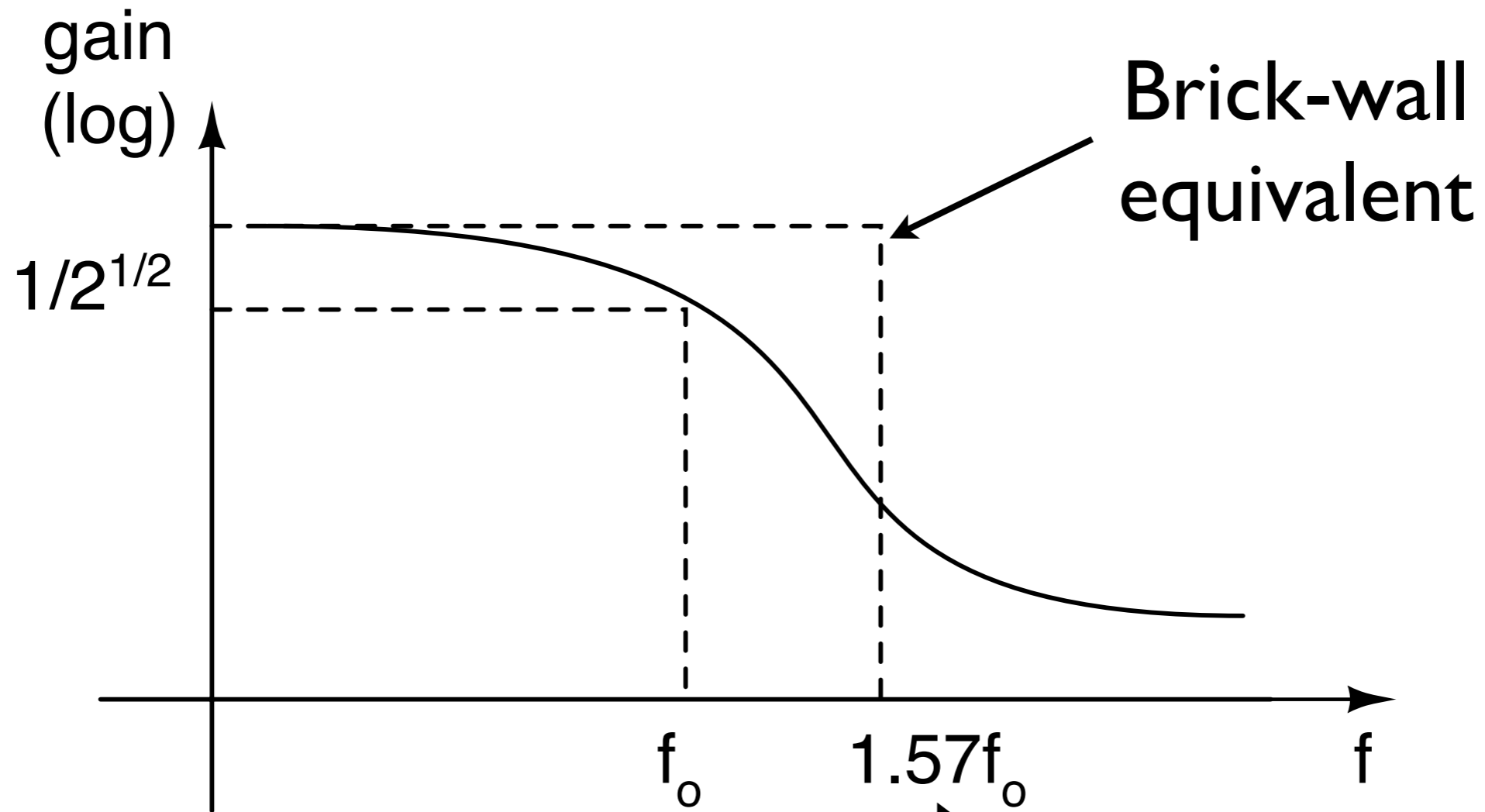

For single-pole system ($n=1$)

Noise-equivalent bandwidth (NEB): $1.57f_0$ for $n=1$;
 for $n=2$, $NEB = 1.11f_0$; for $n=3$, $NEB = 1.05f_0$

Example 7.3 Piece-wise noise integration

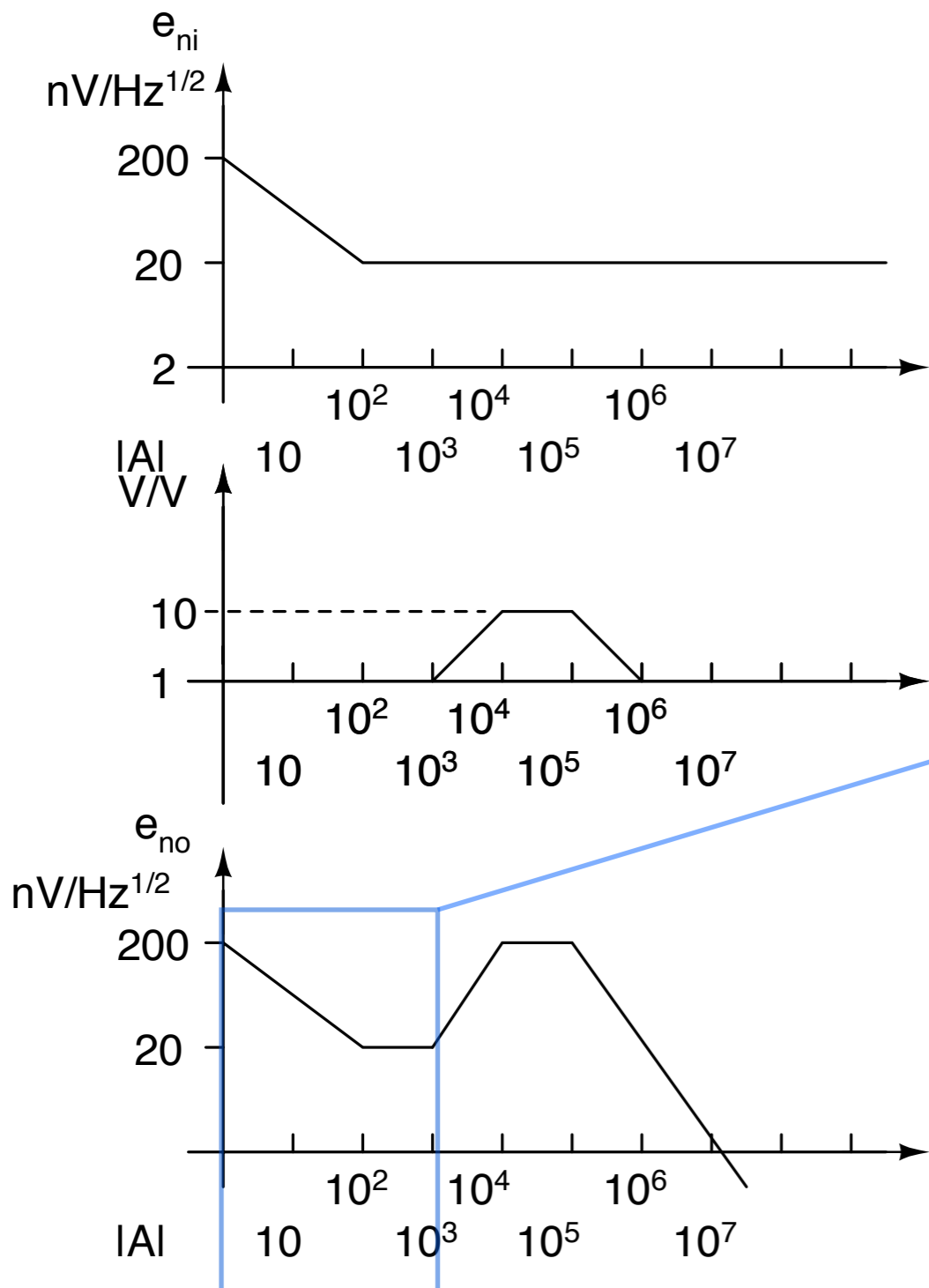

1 Hz to 1kHz:

$$E_n = e_{nw} \sqrt{f_{ce} \ln(f_H/f_L) + f_H - f_L}$$

with

$$e_{nw} = 20 \text{ nV} / \sqrt{\text{Hz}}$$

$$f_{ce} = 100 \text{ Hz} \quad f_L = 1 \text{ Hz}$$

and

$$f_H = 1 \text{ kHz}$$

The result is $E_{no1} = 0.822 \mu\text{V}$.

From 1kHz to 10kHz, e_{no} increases with f at a rate of 1dec/dec. So let

$$e_{no}(f) = \left(20nV/\sqrt{Hz}\right) \times (f/10^3) = 2 \times 10^{-11} f$$

and

$$E_{no2} = 2 \times 10^{-11} \sqrt{\int_{10^3}^{10^4} f^2 df} = 11.5\mu V$$

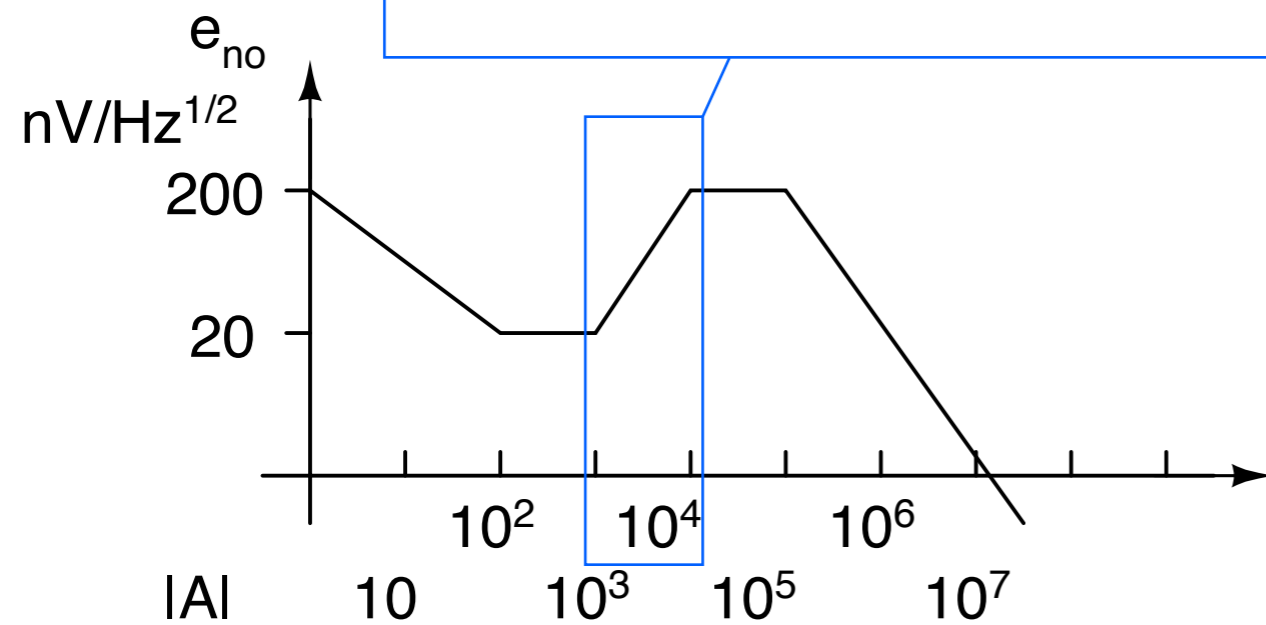

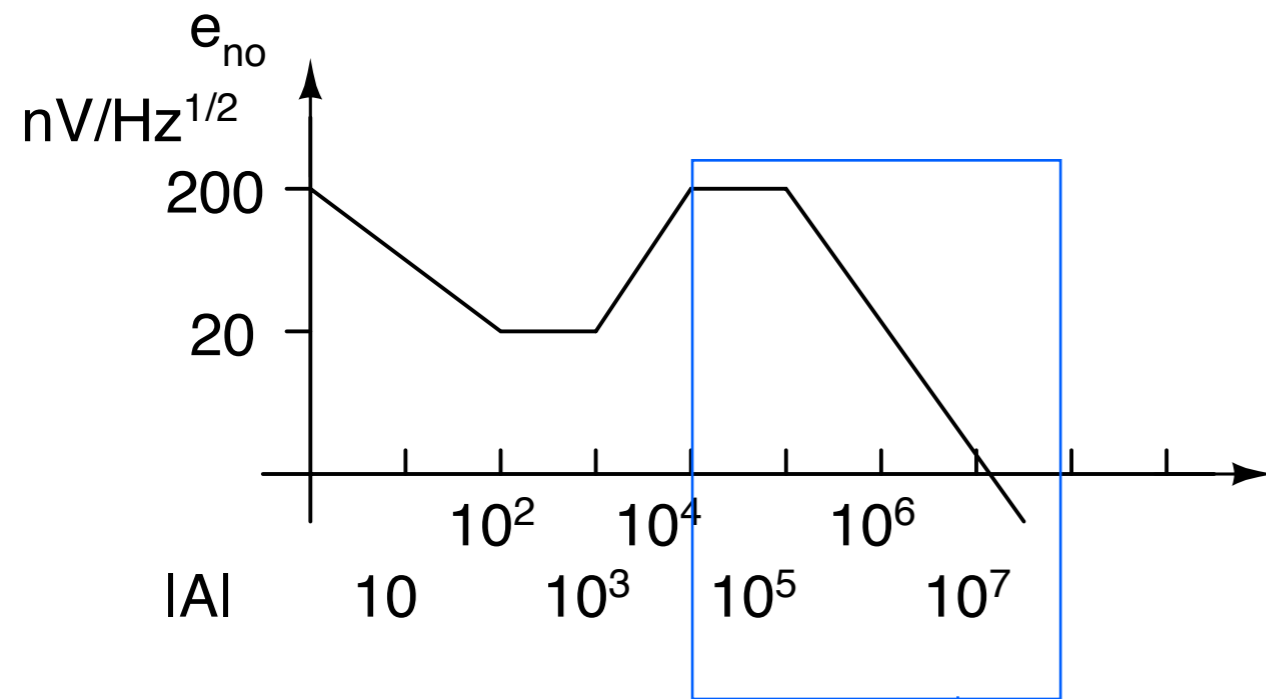

For $f > 10^4 \text{ Hz}$, we have white noise with $e_{nw} = 200 \text{ nV}/\sqrt{\text{Hz}}$ going through a low-pass filter with corner frequency $f_o = 100 \text{ kHz}$. Using

$$E_{no3} = e_{nw} \sqrt{1.57 f_o}$$

$$E_{no3} = (200 \text{ nV}/\sqrt{\text{Hz}}) \times \sqrt{1.57 \times 10^5 - 10^4} = 76.7 \mu\text{V}$$

The total is the root of the sum of the square of the three components

$$E_{no} = \sqrt{E_{no1}^2 + E_{no2}^2 + E_{no3}^2} = 77.5\mu V$$

Pink-noise tangent principle

Lower a line with -0.5 dec/dec slope until it becomes tangent to the noise curve. The main contribution to the output noise will come from the portion of the noise curve that is in the vicinity of the tangent point.

Sources of noise

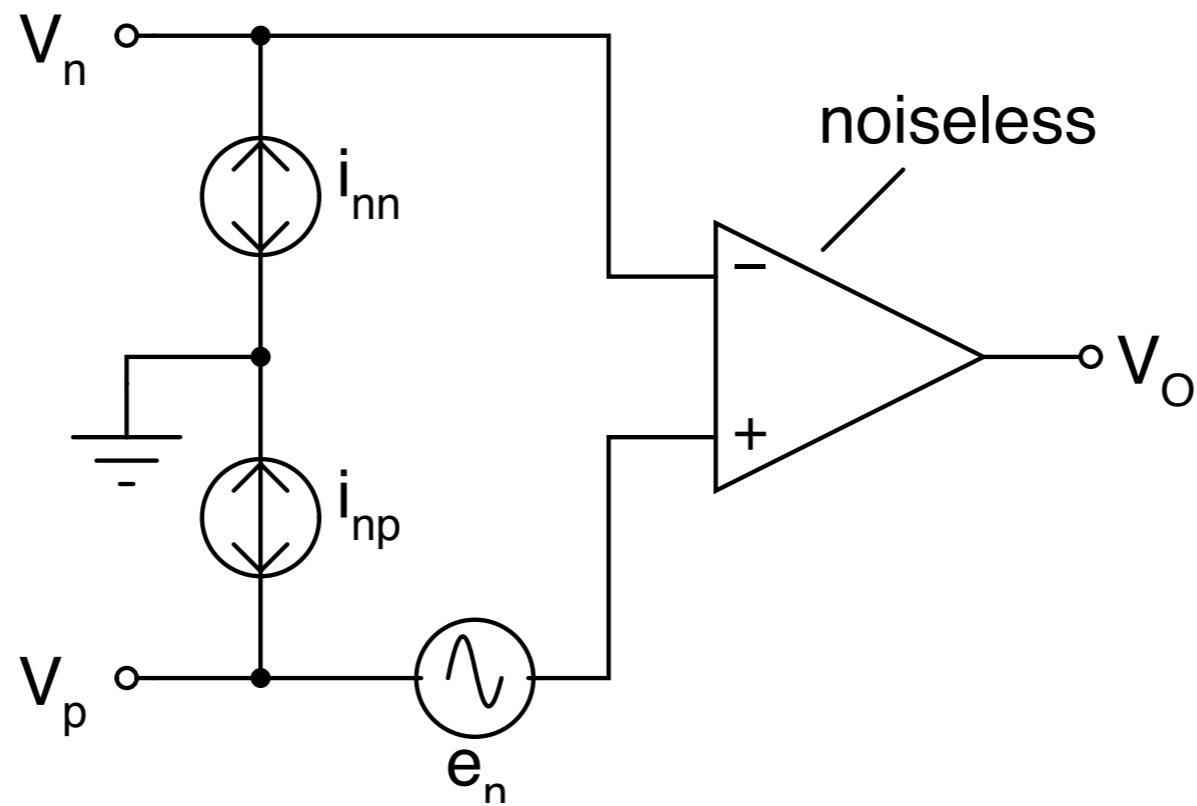
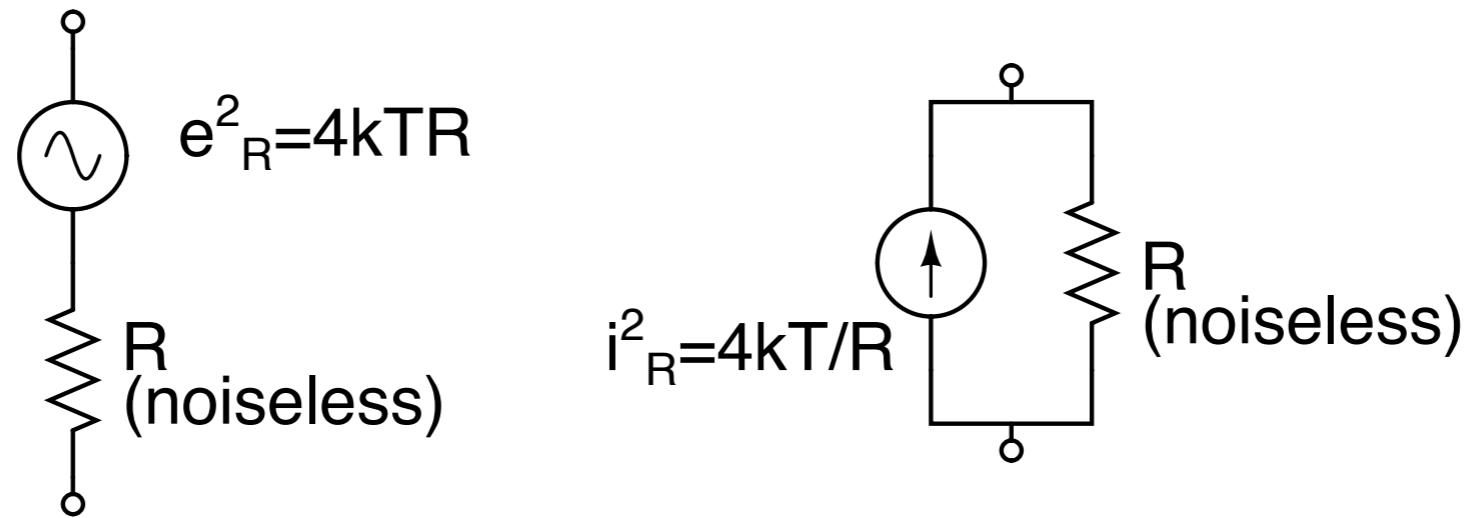

Example 7.7

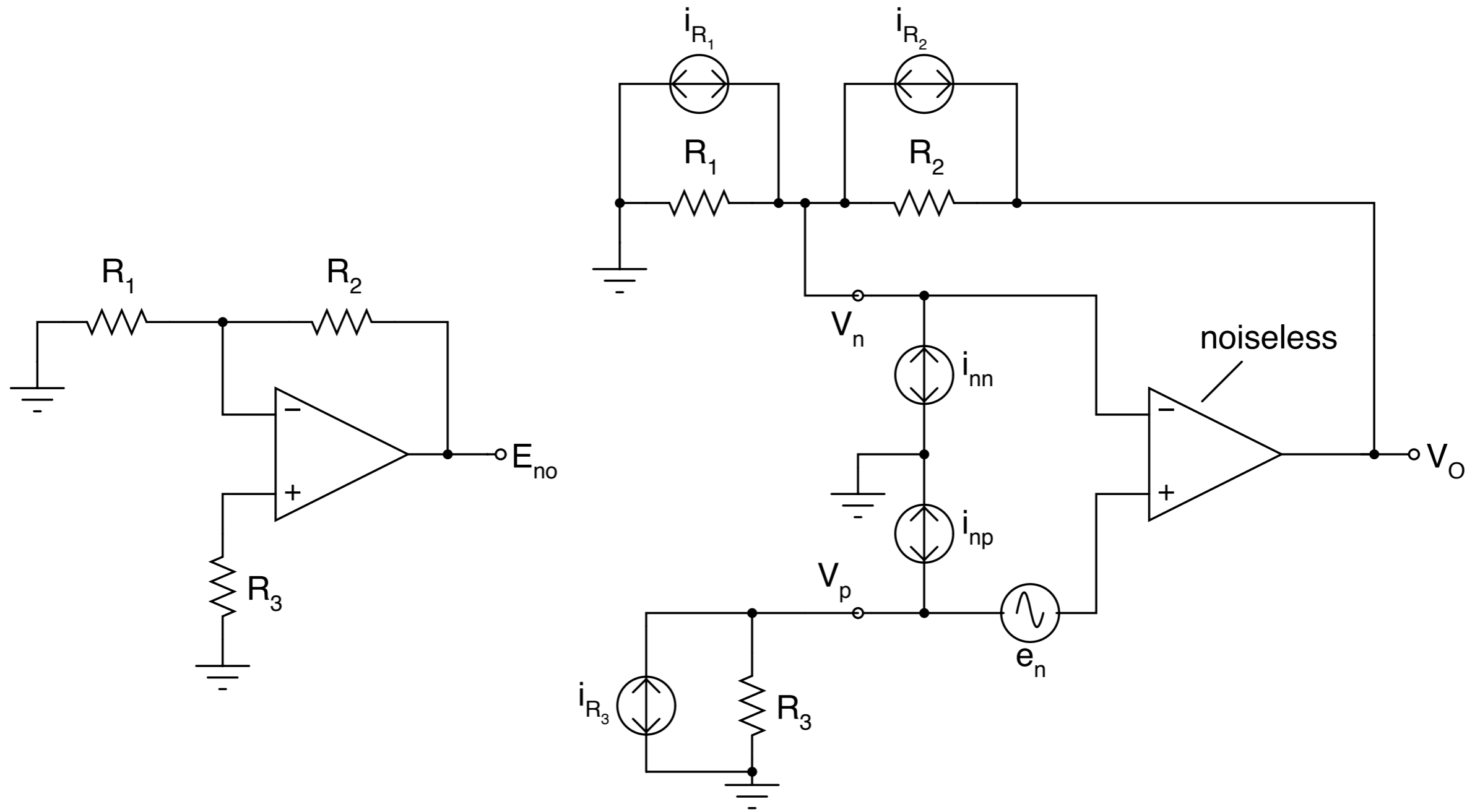

Use superposition to obtain:

$$e_{ni}^2 = e_n^2 + i_{np}^2 R_3^2 + i_{R_3}^2 R_3^2 + (i_{nn}^2 + i_{R_1}^2 + i_{R_2}^2) (R_1 \parallel R_2)^2$$

Using $i_R^2 = \frac{4kT}{R}$,

$$\begin{aligned} e_{ni}^2 &= e_n^2 + i_{np}^2 R_3^2 + 4kT R_3 + \left(i_{nn}^2 + \frac{4kT}{R_1} + \frac{4kT}{R_2} \right) (R_1 \parallel R_2)^2 \\ &= e_n^2 + i_{np}^2 R_3^2 + 4kT R_3 + i_{nn}^2 (R_1 \parallel R_2)^2 + \frac{4kT}{R_1 \parallel R_2} (R_1 \parallel R_2)^2 \\ &= e_n^2 + i_{np}^2 R_3^2 + 4kT R_3 + i_{nn}^2 (R_1 \parallel R_2)^2 + 4kT (R_1 \parallel R_2) \\ &= e_n^2 + i_{np}^2 R_3^2 + i_{nn}^2 (R_1 \parallel R_2)^2 + 4kT (R_3 + R_1 \parallel R_2) \end{aligned}$$

For $i_{np} = i_{nn} = i_n$,

$$e_{ni}^2 = e_n^2 + i_n^2 R_{s2}^2 + 4kTR_s$$

where $R_s = R_3 + R_1 || R_2$, $R_{s2}^2 = R_3^2 + (R_1 || R_2)^2$.

- Setting $R_3 = 0$ reduces noise.
- e_n dominates for low values of R_s : it is called the *short-circuit noise*.
- For $R_s \rightarrow \infty$, $e_{ni} \approx i_n R_{s2}$: i_n is called the *open-circuit noise*.

Noise is amplified by:

$$A_v = \frac{1 + \frac{R_2}{R_1}}{\sqrt{1 + (f/f_A)^2}} = \frac{A_0}{\sqrt{1 + (f/f_A)^2}}$$

The total output rms noise is

$$E_{no} = A_0 \times \sqrt{E_1^2 + E_2^2 + E_3^2 + E_4^2}$$

where

$$E_1^2 = e_{nw}^2 \left(f_{ce} \ln \frac{f_A}{f_L} + 1.57 f_A - f_L \right)$$

$$E_2^2 = R_3^2 i_{npw}^2 \left(f_{cip} \ln \frac{f_A}{f_L} + 1.57 f_A - f_L \right)$$

$$E_3^2 = (R_1 || R_2)^2 i_{nnw}^2 \left(f_{cin} \ln \frac{f_A}{f_L} + 1.57 f_A - f_L \right)$$

and

$$E_4^2 = 4kT(R_3 + R_1 || R_2)(1.57 f_A - f_L)$$

Book says: f_L is $1/T_{obs}$ where T_{obs} is the averaging time used to measure the output.

TI Application note says: take $f_H/f_L = NEB$.

For low-noise designs, use op amps with low e_{nw} and low corner frequencies f_{ci} and f_{cn} .

The *total rms input noise* can be obtained by dividing by the signal dc gain A_{s0}

$$E_{ni} = \frac{E_{no}}{|A_{s0}|}$$

and the signal-to-noise ratio from

$$SNR = 20 \log_{10} \frac{V_{i(rms)}}{E_{ni}}$$

Spice noise source - use with opamp macromodels
that do not model internal noise sources

practically ∞

$$I_D = \frac{i_w^2}{2q}$$

$$KF = 2qf_c$$

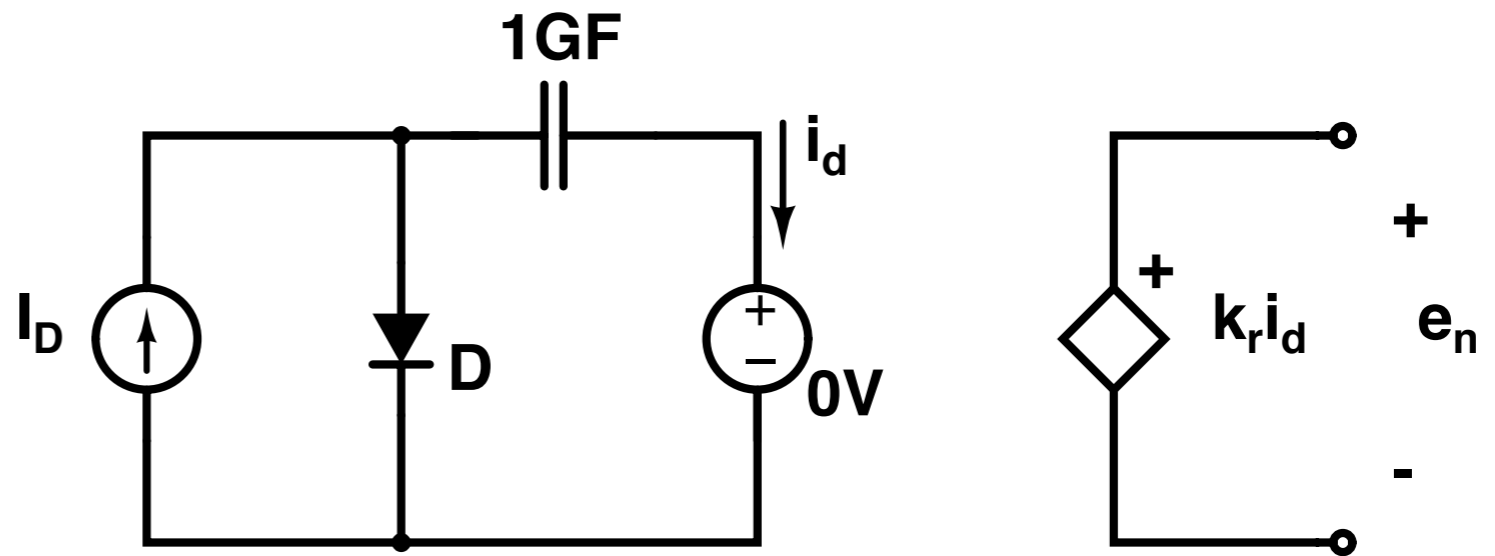

set I_D to get the i_w (white noise level)
set KF to set the f_c (corner frequency)

See netlist on textbook's example 7.6