

# Active Filters

Manuel Toledo Quiñones  
Assistant Professor  
Electrical and Computer Engineering Department  
University of Puerto Rico  
Mayaguez, Puerto Rico

30th October 2002

## 1 Introduction

An electronic filter is a device that transforms an input signal in some specified way to produce the output signal. The filters discussed in this chapter are specified in the frequency domain, and attenuate a range of frequencies.

Filters are classified according to the way groups of frequencies are transmitted, as *low-pass*, *high-pass*, *pass-band*, and *band-stop*. The frequency response of ideal filters are depicted in figure 1.

The transfer function of a real filter will only approximate these response. For the linear filters that we will discuss, filters can be approximated by

$$A_v(s) = A_{v0} \frac{1}{P_n(s)}$$

where  $P_n(s)$  is a polynomial in  $s$  with left half-plane zeros. Filter design techniques will generally rely on representing higher order  $P_n(s)$  as the product of first and second order terms, which find simple implementation.

## 2 Butterworth Filters

### 2.1 Polynomial Generation

Butterworth polynomials can be used to approximate the filter's transfer function. The polynomials  $B_n(s)$  are easier to define by considering the square of the transfer function, i.e. the product

$$A_v(s)A_v(-s) = \frac{A_{v0}^2}{B_n(s)B_n(-s)} = \frac{A_{v0}^2}{1 + (-1)^n s^{2n}}$$

where  $n$  is the filter's order.

Notice that since

$$|A_v(s)|^2 = |A_v(s)A_v(-s)| = \frac{|A_{v0}^2|}{|B_n(s)|^2} = \left| \frac{A_{v0}^2}{1 + (-1)^n s^{2n}} \right|$$

Setting  $s = j \frac{\omega}{\omega_0}$ , where  $\omega_0$  is the filter's corner frequency,

$$|B_n(s)| = \sqrt{1 + (-1)^n (j)^{2n} \left(\frac{\omega}{\omega_0}\right)^{2n}} = \sqrt{1 + \left(\frac{\omega}{\omega_0}\right)^{2n}}$$

For  $\omega \gg \omega_0$ ,  $|B_n(\omega)| \approx \left(\frac{\omega}{\omega_0}\right)^n$ . Thus the filter rolls off at approximately  $n \times 20$  decibels per decade.

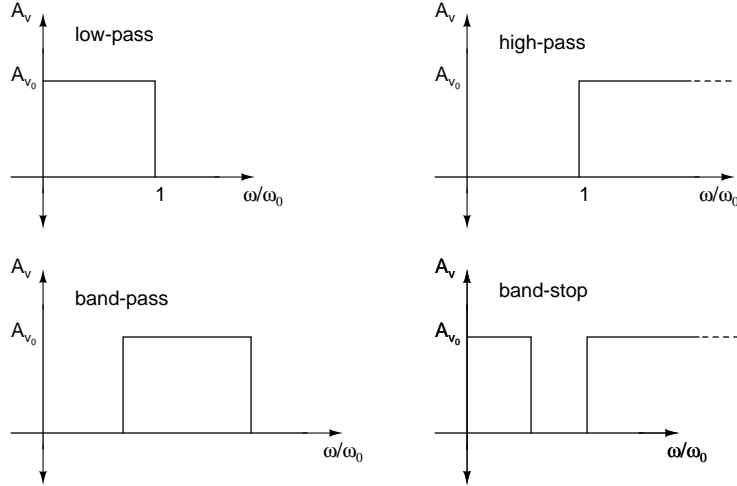

Figure 1: Frequency response of an ideal filter.

### 2.1.1 First Order

For  $n = 1$ , the poles of  $A_v(s)A_v(-s)$  are the roots of

$$1 + (-1)^1 s^{2 \times 1} = 1 - s^2 = 0$$

which are  $s_{1,2} = \pm 1$ . Since  $B_1(s)$  must be stable in order to be used in a filter, its root must be the one at  $s = -1$ . Thus

$$B_1(s) = s + 1$$

### 2.1.2 Second and Higher Even Orders

Second order filters will have

$$B_2(s)B_2(-s) = 1 + (-1)^2 s^{2 \times 2} = 1 + s^4$$

Setting this to zero,

$$s^4 = -1$$

Since we are dealing with complex numbers (remember that  $s = j(\omega/\omega_0)$ ), we can use exponential notation to represent  $-1$ ,

$$-1 = 1e^{j(m360^\circ + 180^\circ)}$$

where  $m$  is a constant taking values from 0 to  $2n - 1 = 4 - 1 = 3$ . Thus, the four roots of  $B_4$  are

$$s = 1e^{j(m90^\circ + 45^\circ)}$$

which yields, for  $m = 0, 1, 2$  and  $3$ ,  $s_0 = e^{j45^\circ}$ ,  $s_1 = e^{j135^\circ}$ ,  $s_2 = e^{j225^\circ}$  and  $s_3 = e^{j315^\circ}$ , respectively. These four poles are shown in figure 2.1.2. From the figure, we observe that there are two stable and unstable roots.

Since these roots are the poles of  $\frac{1}{B_2(s)B_2(-s)}$  and we know that the poles of  $\frac{1}{B_2(s)}$  must be stable in order to have a stable filter, we conclude that the roots of  $B_2(s)$  should be  $s_1 = e^{j135^\circ} = -0.707 + j0.707$  and  $s_2 = e^{j225^\circ} = -0.707 - j0.707$ . Thus

$$B_2(s) = (s + 0.707 - j0.707)(s + 0.707 + j0.707) = s^2 + 1.414s + 1$$

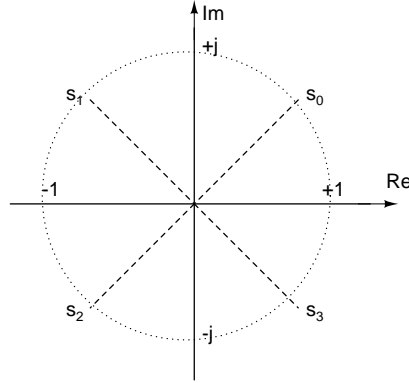

Figure 2: Poles of  $B_2(s)B_2(-s)$ .

For an arbitrary even order  $n$ , using the above arguments

$$s^{2n} = 1e^{j(m360^\circ+180^\circ)}$$

and thus the roots are at

$$s = 1e^{j((m180^\circ+90^\circ)/n)}$$

where  $m = 0, 1, \dots, n - 1$ . Selecting only the roots in the left side of the complex plane,

$$90^\circ < \frac{m(180^\circ) + 90^\circ}{n} < 90^\circ$$

which can be solved to obtain a range  $\frac{n-1}{2} \leq m \leq \frac{3n-1}{2}$ .

### 2.1.3 Third and Higher Odd Order

For  $n = 3$ ,

$$B_3(s)B_3(-s) = 1 + (-1)^3 s^{2*3} = 1 - s^6$$

Setting this to zero,

$$s^6 = 1 = 1e^{j(m360^\circ)}$$

or

$$s = 1e^{j(m60^\circ)}$$

with  $m$  taking values 0, 1, 2, 3, 4 and 5. Thus we get the roots shown if figure 2.1.3.

Selecting the three stable poles, we conclude that the roots of  $B_3$  are  $s = -1, -0.5 + j.866$  and  $-0.5 - j.866$ . Thus

$$B_3(s) = (s + 1)(s^2 + s + 1)$$

We can extend the above argument to an arbitrary odd order  $n$ , and conclude that the roots of  $B_n$  will be at

$$s = 1e^{j((m180^\circ)/n)}$$

where  $m$  assume integer values from 0 to  $n - 1$ . For poles on the left half of the complex plane,  $\frac{n}{2} \leq m \leq \frac{3n}{2}$ .

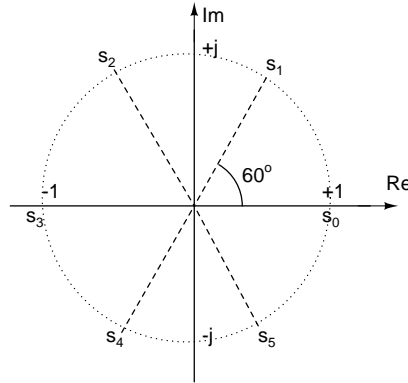

Figure 3: Poles of  $B_3(s)B_3(-s)$ .

### 2.1.4 Table of Polynomials

For easier implementation, it is convenient to express Butterworth Polynomials as product of first and second order (quadratic) polynomials. The following table gives the Butterworth polynomials from order 1 to 7.

n	$B_n(s)$
1	$s + 1$
2	$s^2 + 1.414s + 1$
3	$(s + 1)(s^2 + s + 1)$
4	$(s^2 + 0.765s + 1)(s^2 + 1.848s + 1)$
5	$(s + 1)(s^2 + 0.618s + 1)(s^2 + 1.618s + 1)$
6	$(s^2 + 0.518s + 1)(s^2 + 1.414s + 1)(s^2 + 1.932s + 1)$
7	$(s + 1)(s^2 + 0.445s + 1)(s^2 + 1.247s + 1)(s^2 + 1.802s + 1)$

The quadratic factors have the form

$$s^2 + 2\zeta s + 1$$

where half of the coefficient of  $s$  is represented by  $\zeta$  and is called the *damping ratio*.

## 3 Filter Implementation

From the above discussion, we can see that an arbitrary order filter can be implemented by cascading first and second order stages. If the filter's order is odd, a first order stage must be included. The circuit shown in figure 3.1 can be used. The voltage gain of this stage is

$$A_v(s) = \frac{A_{v0}}{s/\omega_0 + 1}$$

where  $A_{v0} = 1 + R_2/R_1$  and  $\omega_0 = 1/RC$ .

### 3.1 First Order Stage

### 3.2 Sallen-Key Filters

One way of implementing a second order, or quadratic, stage is to use the so called *Sallen-Key*. The circuit for a general quad filter is shown in figure 3.2, where  $z_{1,2,3,4}$  are impedances, and  $R_{1,2}$  set the gain of the

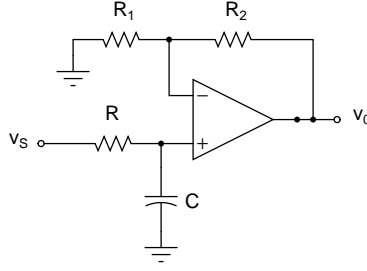

Figure 4: First order filter.

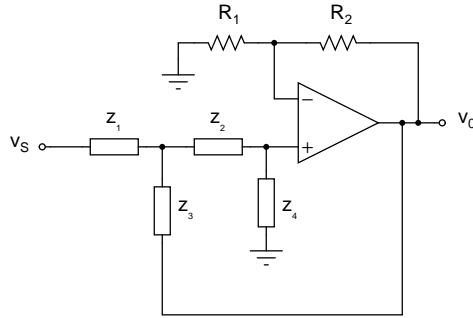

Figure 5: Quadratic filter.

non-inverting amplifier.

To obtain the transfer function of this filter, invoke the superposition principle at the non-inverting input to obtain

$$v_+ = \frac{z_4}{z_2 + z_4} \left( \frac{z_3(z_2 + z_4)}{z_1(z_2 + z_3 + z_4) + z_3(z_2 + z_4)} v_S + \frac{z_1(z_2 + z_4)}{z_3(z_1 + z_2 + z_4) + z_1(z_2 + z_4)} v_O \right)$$

Setting  $v_+ = V_O/A_{v0}$  and rearranging gives

$$\frac{v_O}{A_{v0}} = \frac{z_3 z_4}{z_1(z_2 + z_3 + z_4) + z_3(z_2 + z_4)} v_S + \frac{z_1 z_4}{z_3(z_1 + z_2 + z_4) + z_1(z_2 + z_4)} v_O$$

or

$$\left( 1 - \frac{z_1 z_4}{z_3(z_1 + z_2 + z_4) + z_1(z_2 + z_4)} \right) v_O = \frac{z_3 z_4}{z_1(z_2 + z_3 + z_4) + z_3(z_2 + z_4)} v_S$$

which, after rearranging yields

$$\frac{v_O}{v_S} = \frac{z_3 z_4}{z_3(z_1 + z_2 + z_4) + z_1 z_2 + z_1 z_4(1 - A_{v0})} A_{v0}$$

where  $A_{v0} = 1 + R_2/R_1$ .

To obtain a Sallen-Key filter, let  $z_1 = z_2 = R$  and  $z_3 = z_4 = \frac{1}{sC}$ . Then

$$\frac{v_O}{v_S} = \frac{\frac{1}{s^2 C^2}}{\frac{1}{sC}(2R + \frac{1}{sC}) + R^2 + \frac{R}{sC}(1 - A_{v0})} A_{v0}$$

which can be rearranged to obtain

$$\frac{v_O}{v_S} = \frac{A_{v0}}{s^2(RC)^2 + (3 - A_{v0})(RC)s + 1}$$

Letting  $RCs$  represent a scaled frequency  $s' = j\omega'$ ,

$$\frac{v_O}{v_S} = \frac{A_{v0}}{s'^2 + (3 - A_{v0})s' + 1}$$

whose denominator is of the form

$$s^2 + 2\zeta s + 1$$

Thus, the Sallen-Key filter can be used to implement the quadratic factors in a Butterworth filter by just setting  $3 - A_{v0} = 2\zeta$ . The filter's corner frequency is given by  $1/RC$ .

### 3.3 Low-pass Examples

1. Design a fourth-order Butterworth with a cut-off frequency of 1kHz.
2. Design a fifth-order Butterworth with a cut-off frequency of 1kHz.

### 3.4 High-pass Filters

If, in a low-pass filter,  $s/\omega_0$  is replaced by  $\omega_0/s$ , a high-pass filter is obtained. In the above filter design strategy, this is equivalent to interchanging the positions of capacitors  $C$  and resistors  $R$ . Thus, an easy way to design a high-pass filter is to design a low-pass with similar specifications, and then exchanging the positions of  $R$  and  $C$ .

### 3.5 Finding the Filter's Order and Corner Frequency

If the filter's specs are given in terms of attenuation at two frequencies, the filter order must be determined. Assume that the spec requires a gain  $a_1$  at frequency  $\omega_1$  and  $a_2$  at frequency  $\omega_2$ . We can write

$$|A_v(\omega_1)| = a_1 = \frac{A_{v0}}{\sqrt{1 + \left(\frac{\omega_1}{\omega_0}\right)^2}}$$

A similar expression can be written at  $\omega_2$ .

To design the filter, we need to determine  $n$  and  $\omega_0$ . Assuming that the d.c gain is specified, then this can be done as follows. Rearrange the above equation to obtain

$$\left(\frac{\omega_1}{\omega_0}\right)^{2n} = \left(\frac{A_{v0}}{a_1}\right)^2 - 1$$

Taking the logarithm and rearranging,

$$2n \log \omega_1 - 2n \log \omega_0 = \log \left( \left( \frac{A_{v0}}{a_1} \right)^2 - 1 \right)$$

A similar equation can be written at  $\omega_2$ ,

$$2n \log \omega_2 - 2n \log \omega_0 = \log \left( \left( \frac{A_{v0}}{a_2} \right)^2 - 1 \right)$$

Subtracting these two expressions and solving for  $n$  we obtain that

$$n = \frac{\log \left( \frac{\left( \frac{A_{n0}}{a_1} \right)^2 - 1}{\left( \frac{A_{n0}}{a_2} \right)^2 - 1} \right)}{2n \log \left( \frac{\omega_1}{\omega_2} \right)}$$

We should choose  $n$  to be the smallest integer larger or equal to the value obtained in this way. We can also find  $\omega_0$  by substituting the calculated  $n$  in one of the above expressions.

### 3.6 Practice Problems

1. Find the order  $n$  of a Butterworth filter that exhibit at least 1 dB attenuation at 1kHz and at least 20 dB attenuation at 1.3 kHz. Assume the filter's dc gain to be 0 dB. (Ans.  $n = 12$ )
2. Find the attenuation at 5 kHz for the filter in the previous problem.