

Non-linear Circuits

INEL 5207 - Chapter 9 - Spring 2011

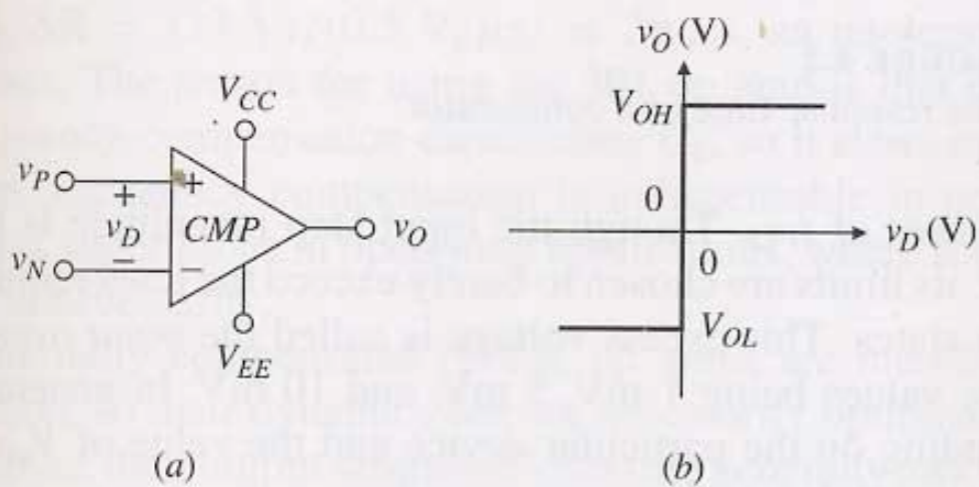

FIGURE 9.1
Voltage-comparator symbolism and ideal VTC. (All node voltages are referenced to ground.)

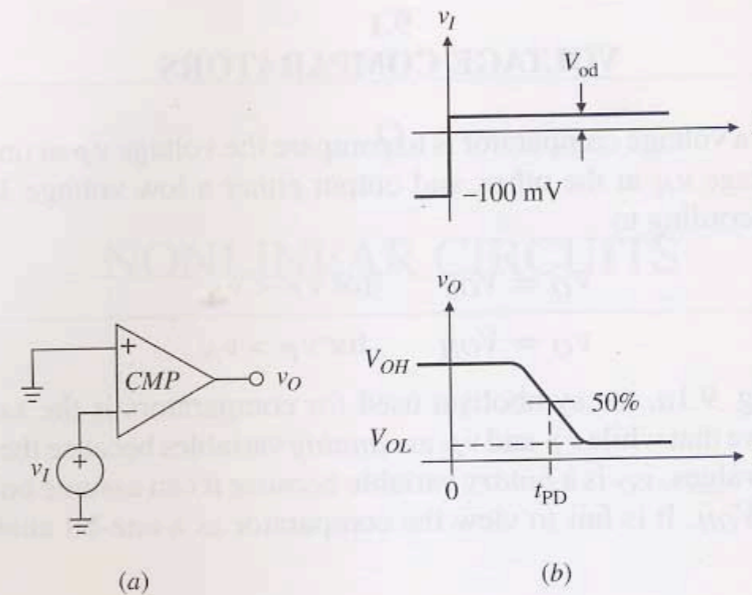

FIGURE 9.2
The response time of a comparator.

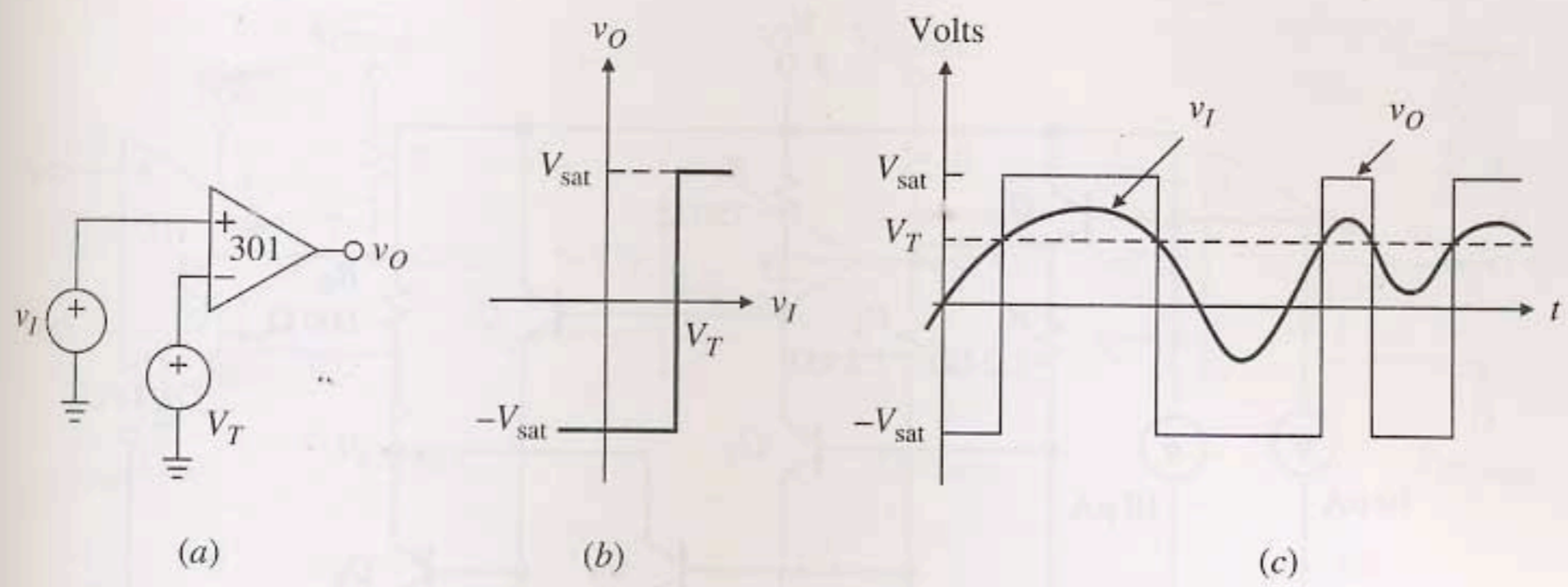

FIGURE 9.3
Threshold detector.

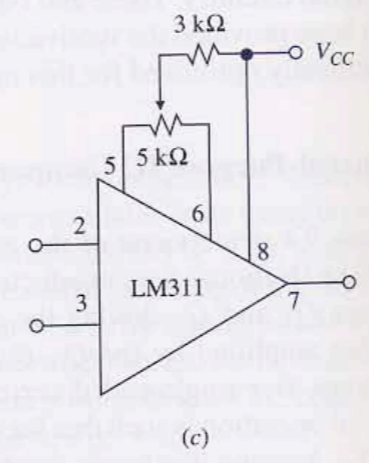
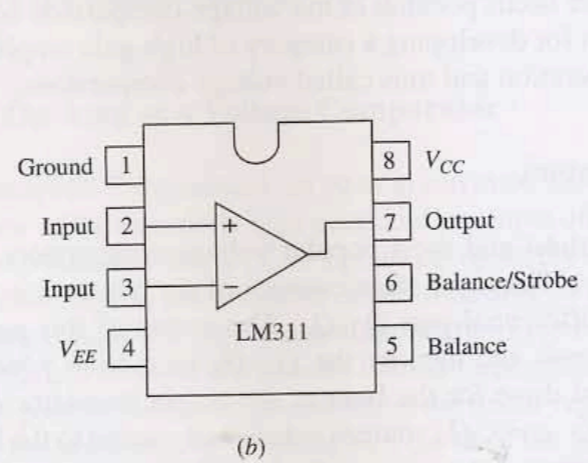
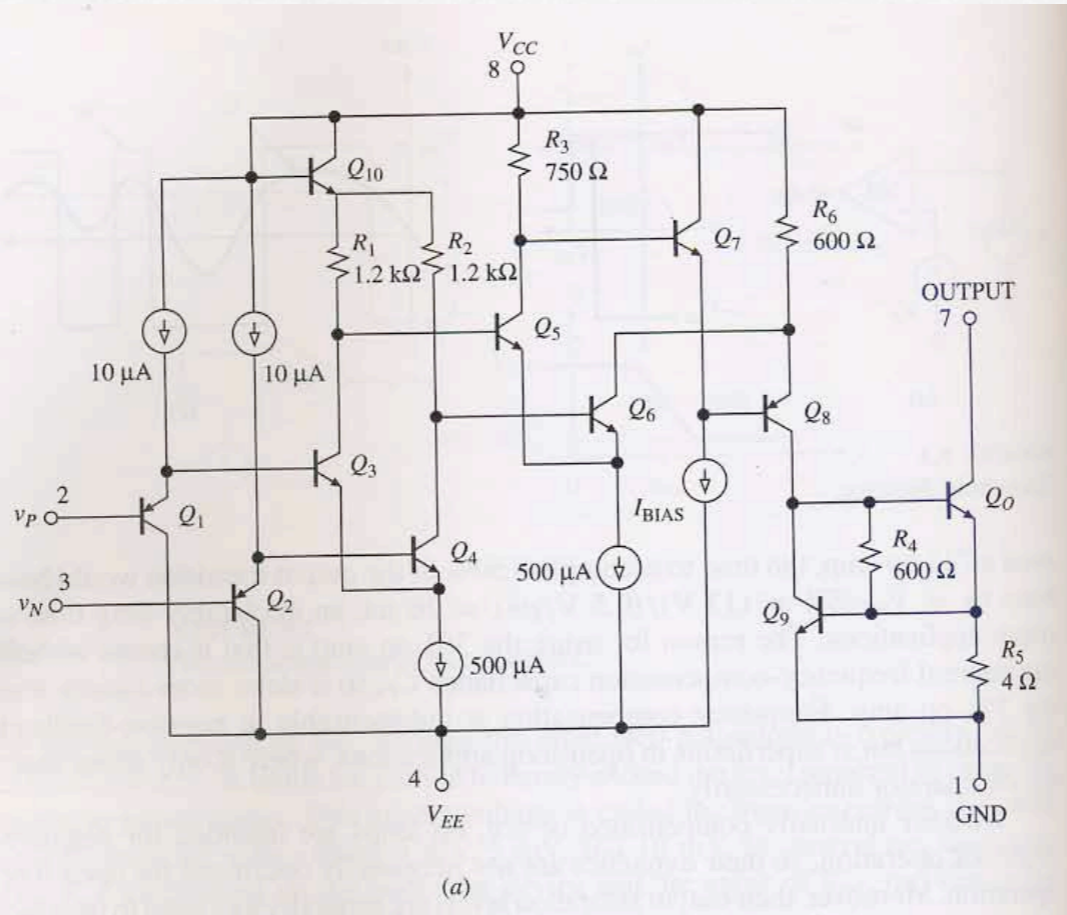

FIGURE 9.4 The LM311 voltage comparator: (a) simplified circuit diagram, (b) pinout, and (c) offset nulling. (Courtesy of National Semiconductor.)

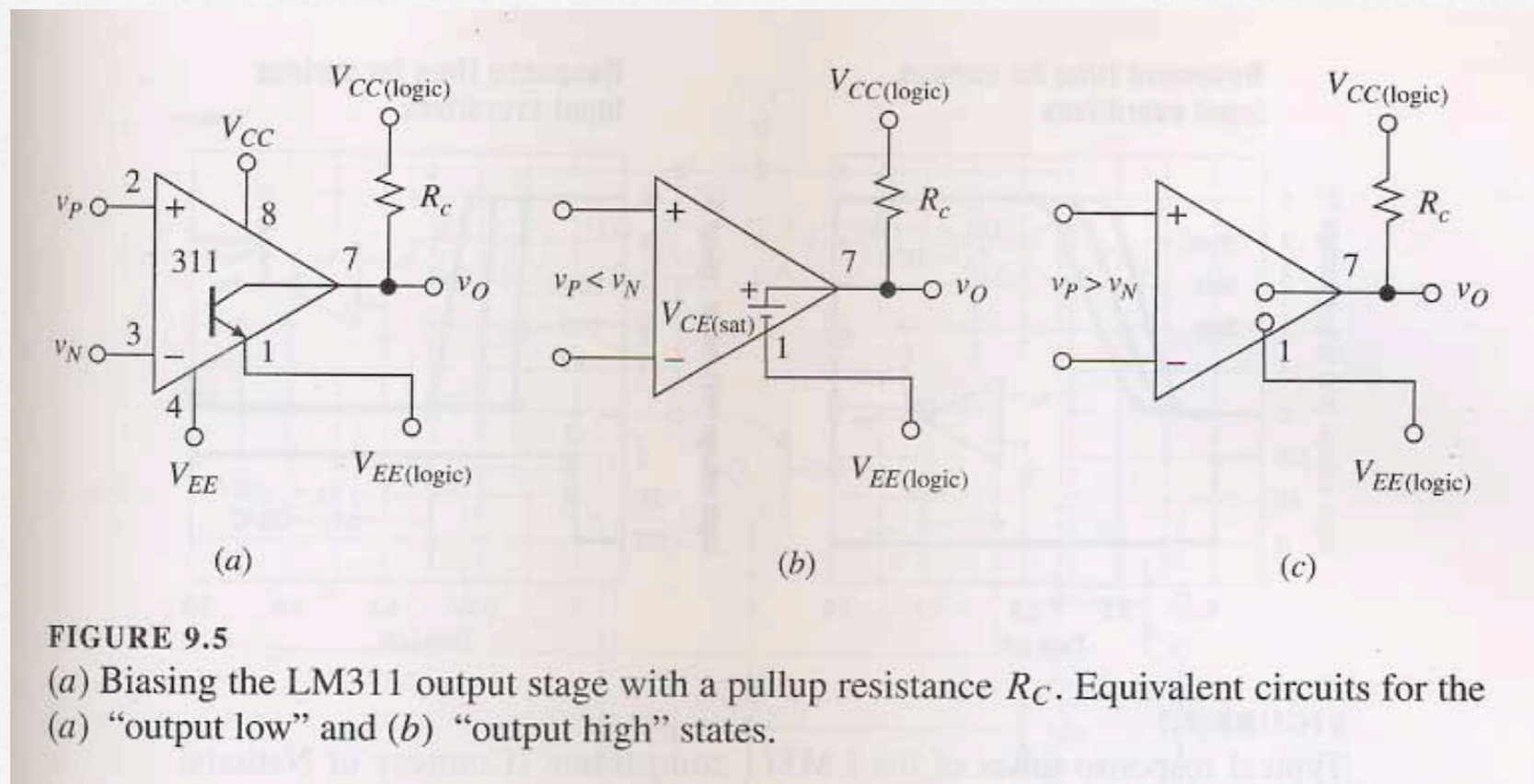
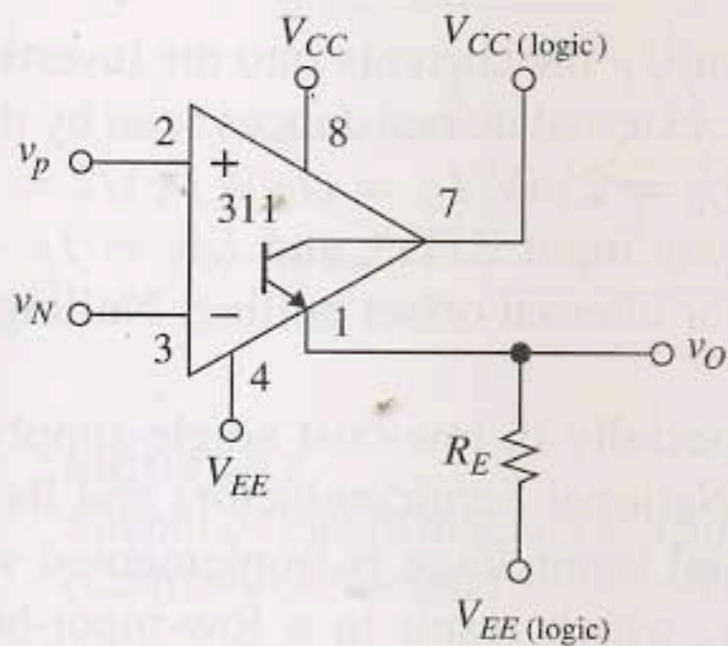

FIGURE 9.5

(a) Biasing the LM311 output stage with a pullup resistance R_C . Equivalent circuits for the (a) "output low" and (b) "output high" states.



(a)

Transfer function

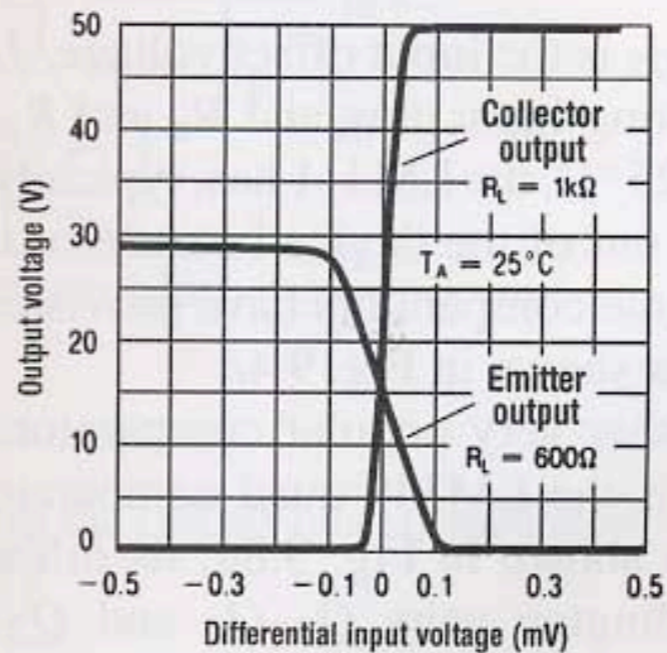

(b)

FIGURE 9.6

(a) Biasing the LM311 output stage with a pull-down resistance R_E . (b) VTC comparison for pullup and pull-down biasing. (Courtesy of National Semiconductor.)

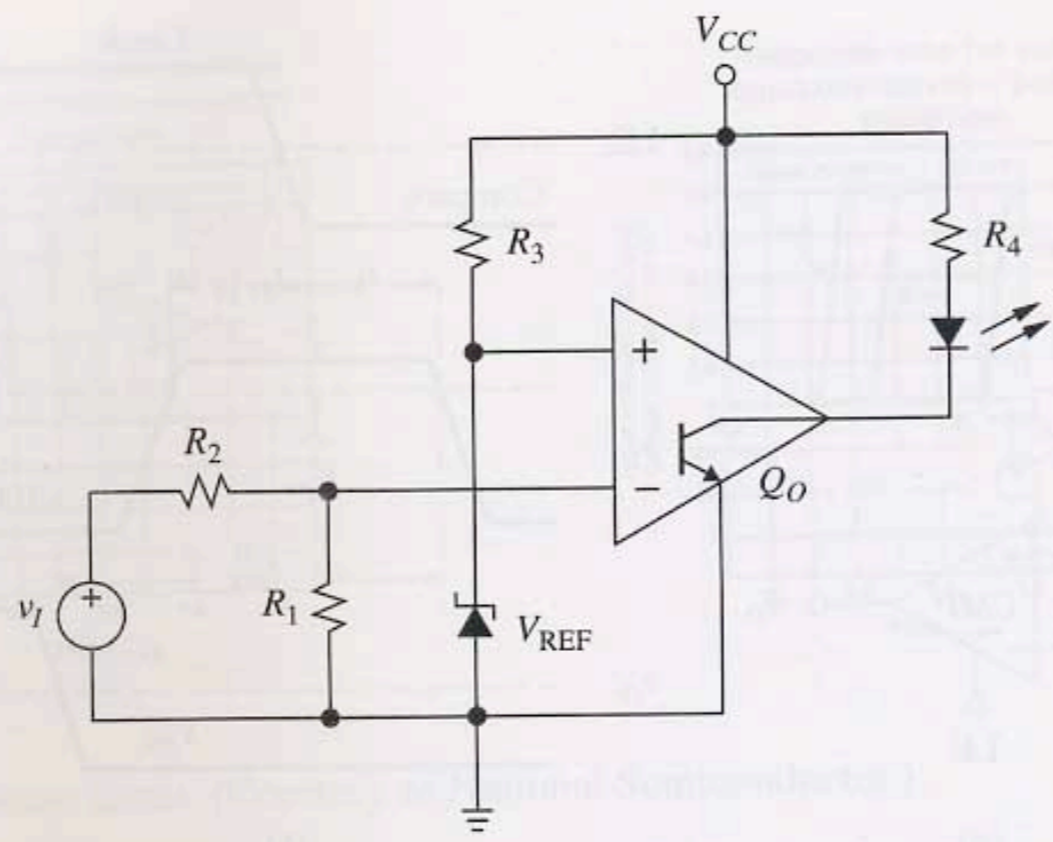

FIGURE 9.11
Basic level detector with optical indicator.

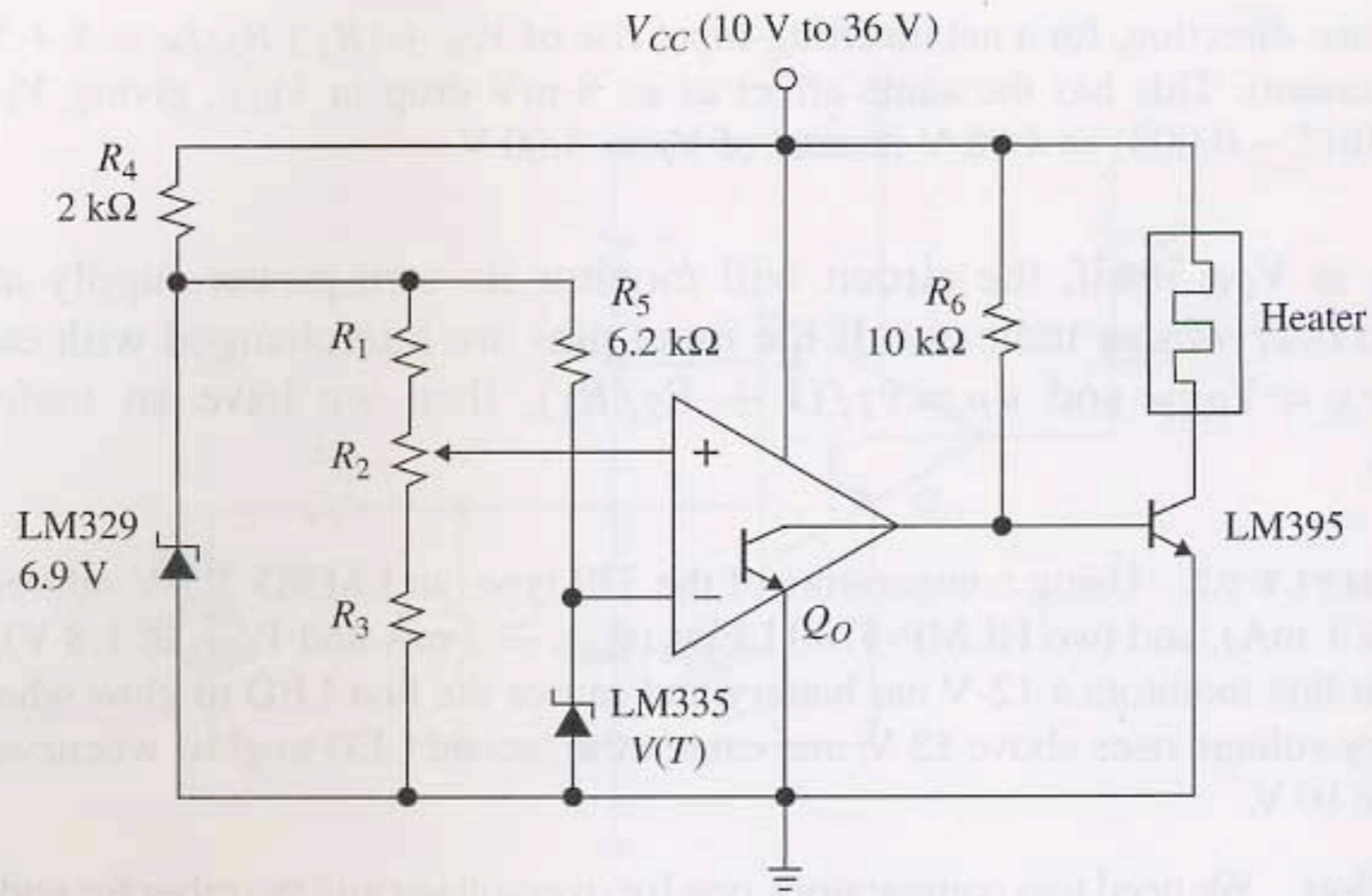

FIGURE 9.12
On-off temperature controller.

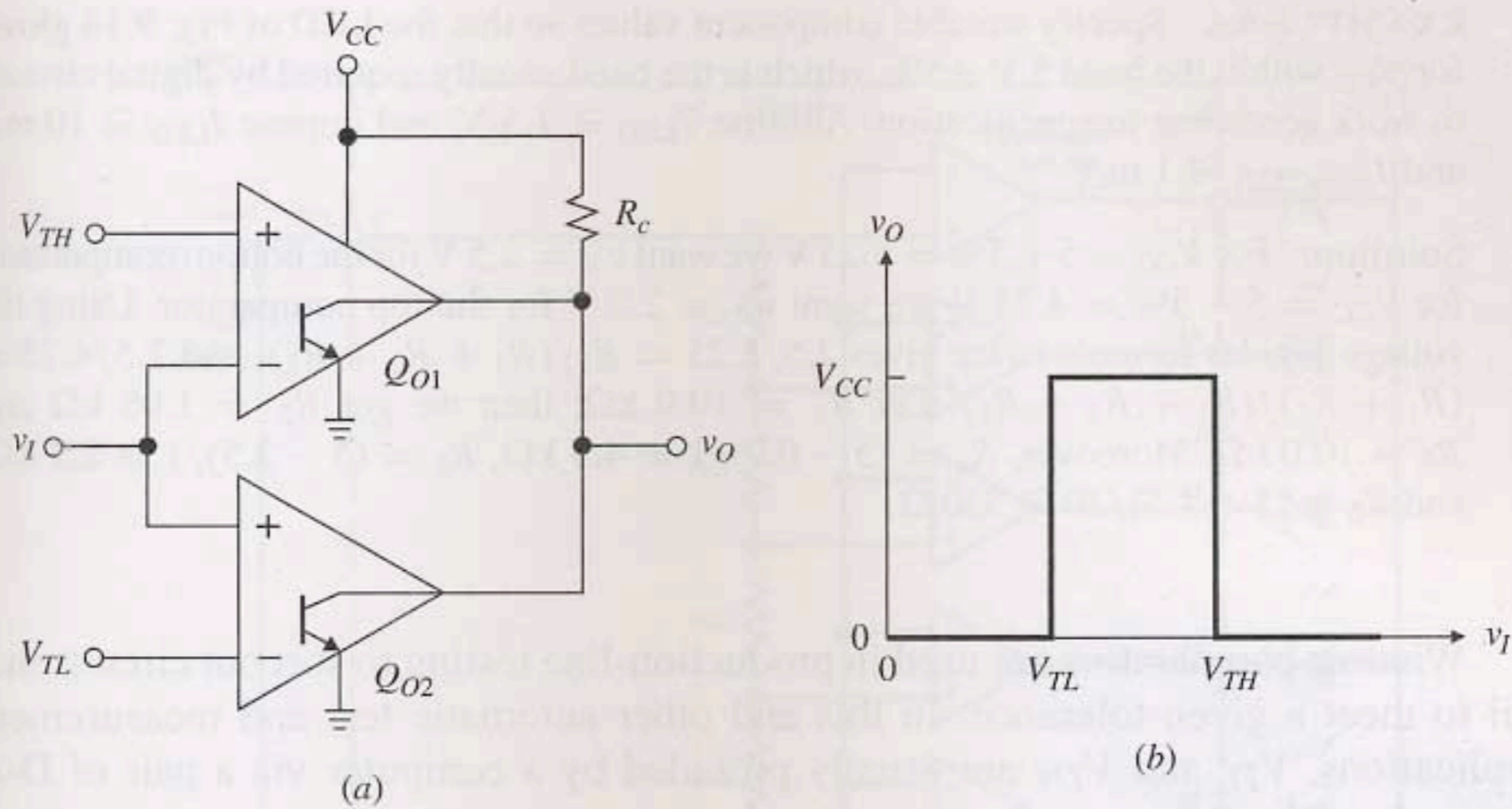

FIGURE 9.13
Window detector and its VTC.

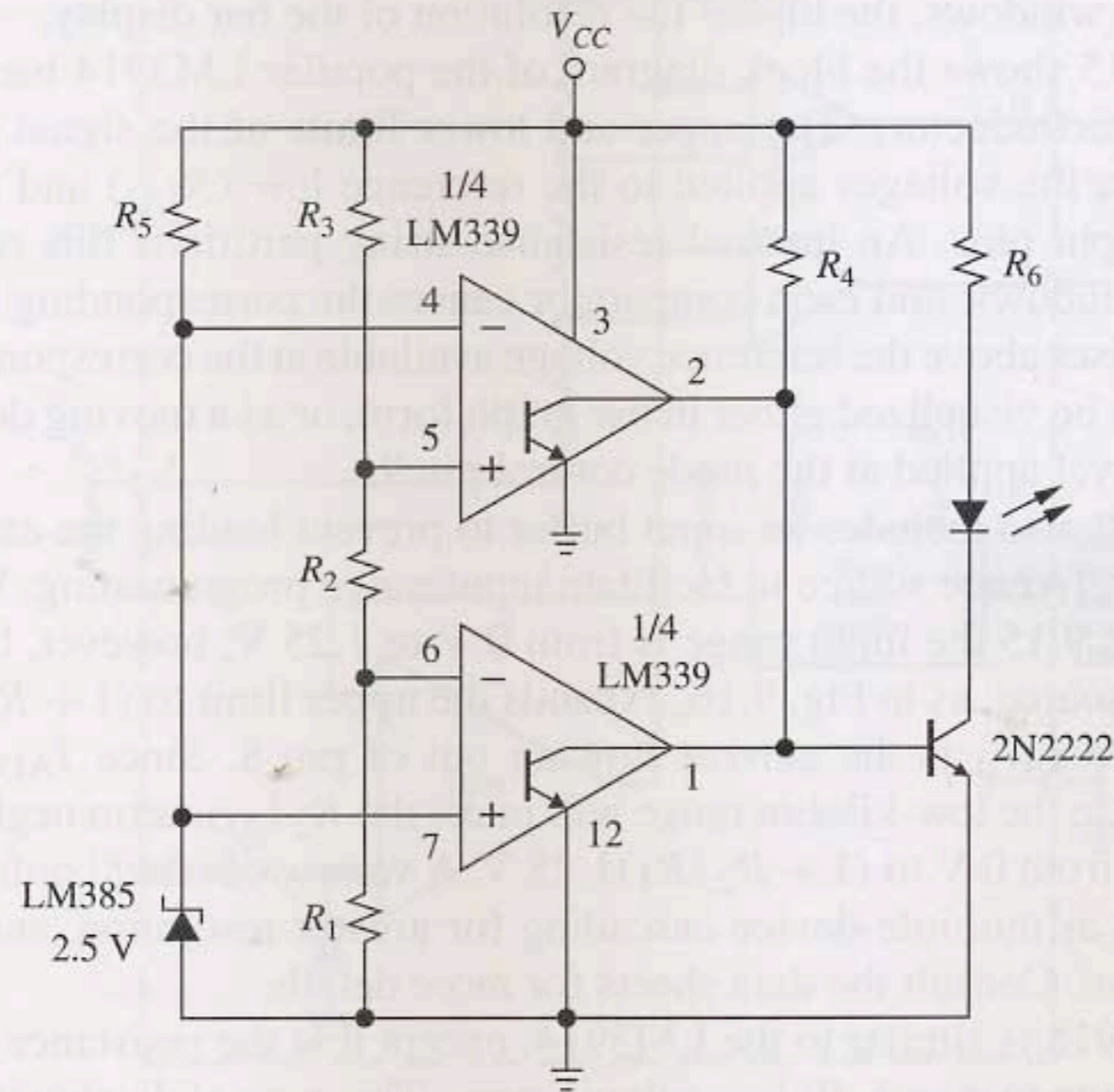

FIGURE 9.14
 Power-supply monitor; LED glows as long as V_{CC} is within specification.

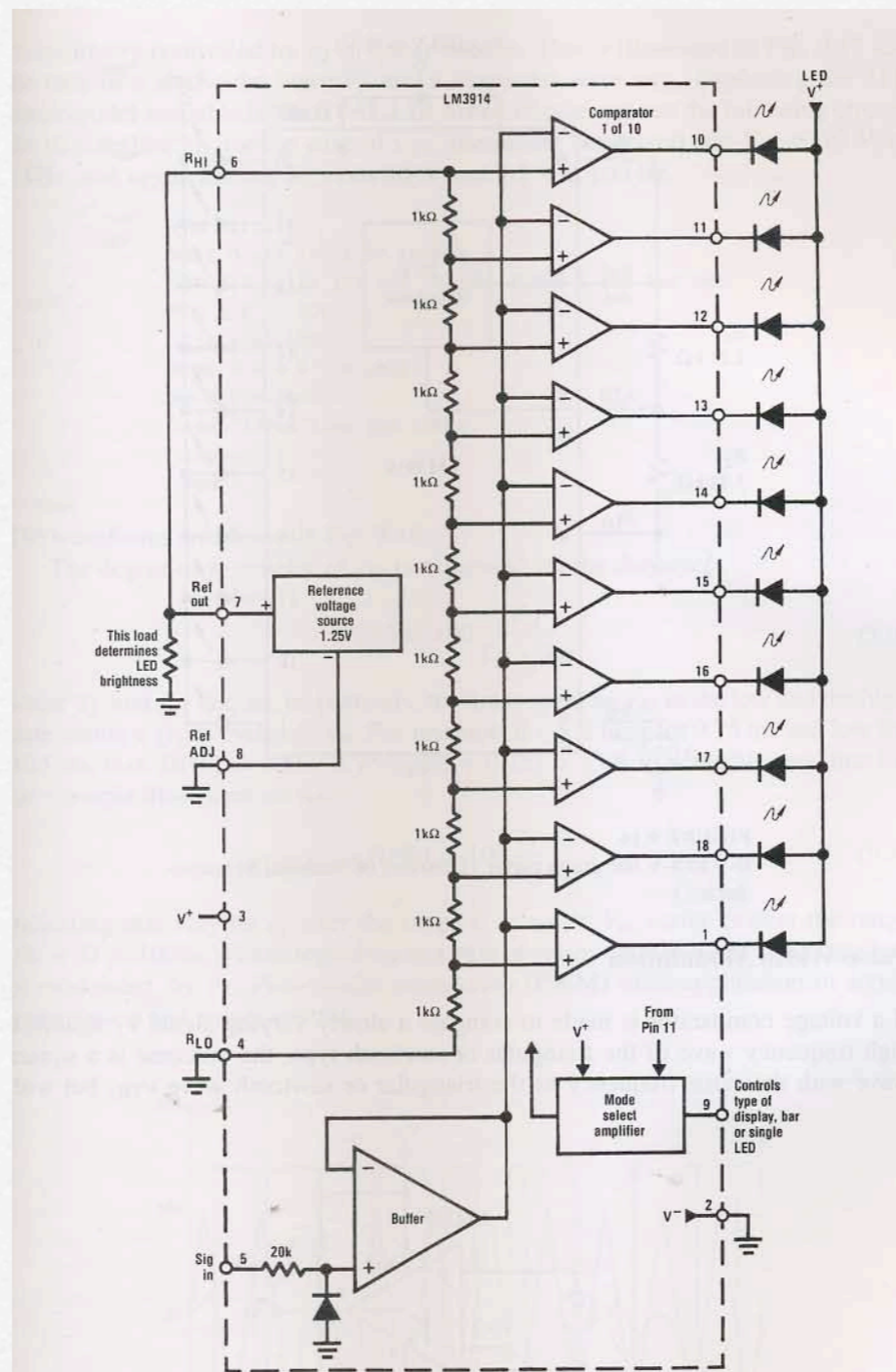

FIGURE 9.15
The LM3914 dot/bar display driver. (Courtesy of National Semiconductor.)

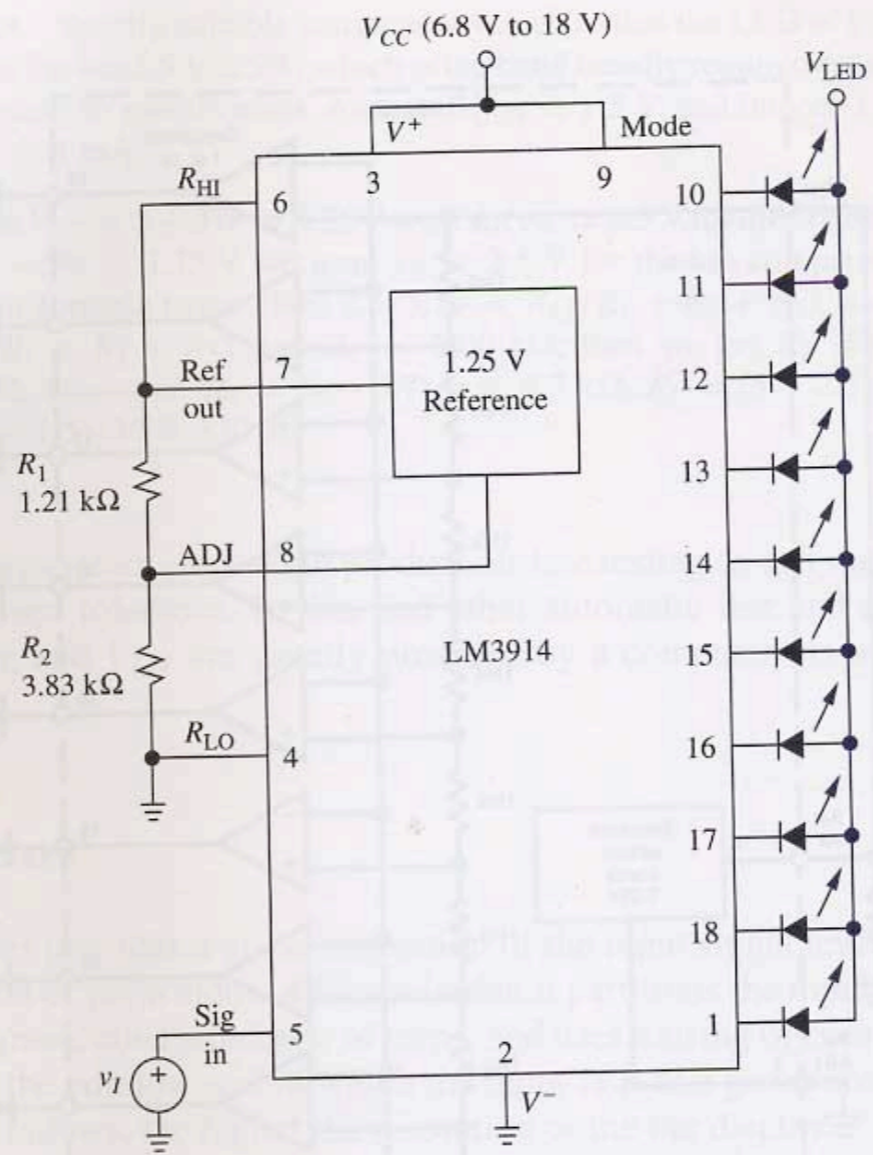

FIGURE 9.16
0-V to 5-V bar graph meter. (Courtesy of National Semicon-
ductor.)

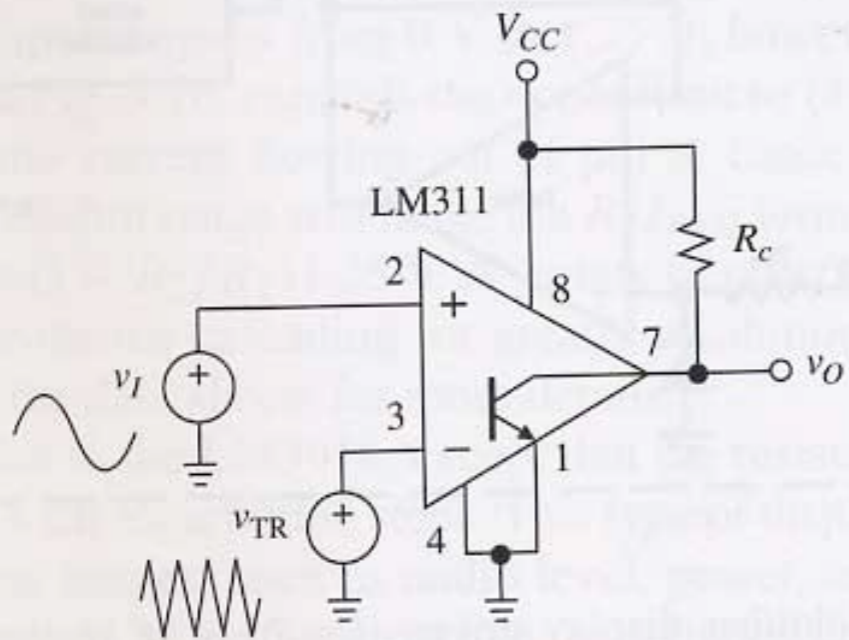

FIGURE 9.17
 Modulating a high-frequency triangular wave v_{TR} with a low-frequency signal v_I .

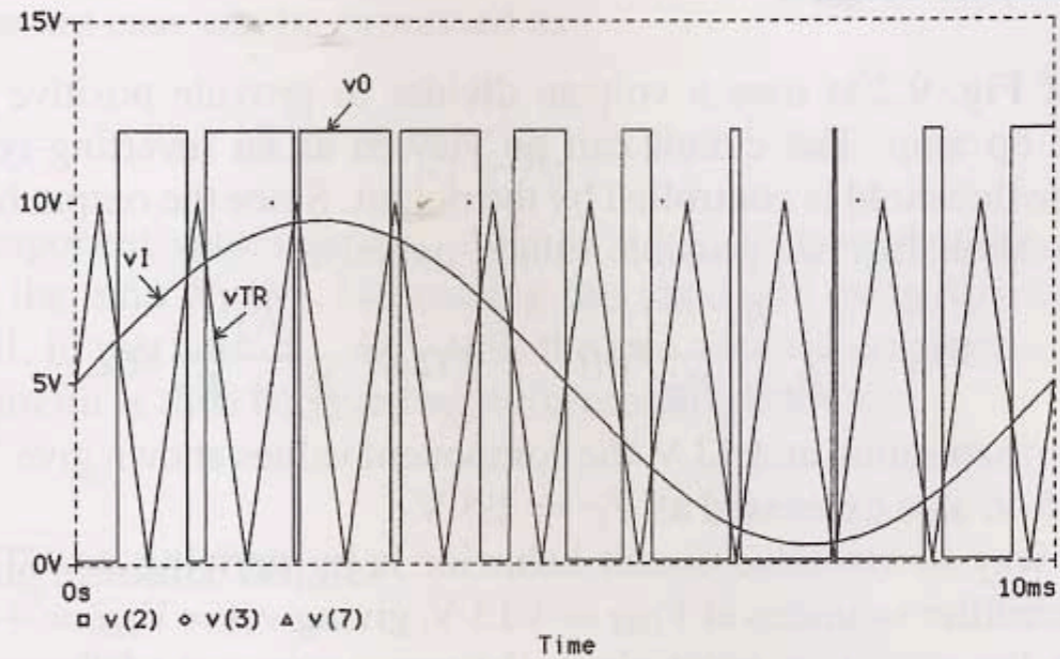

FIGURE 9.18
 PWM waveforms.

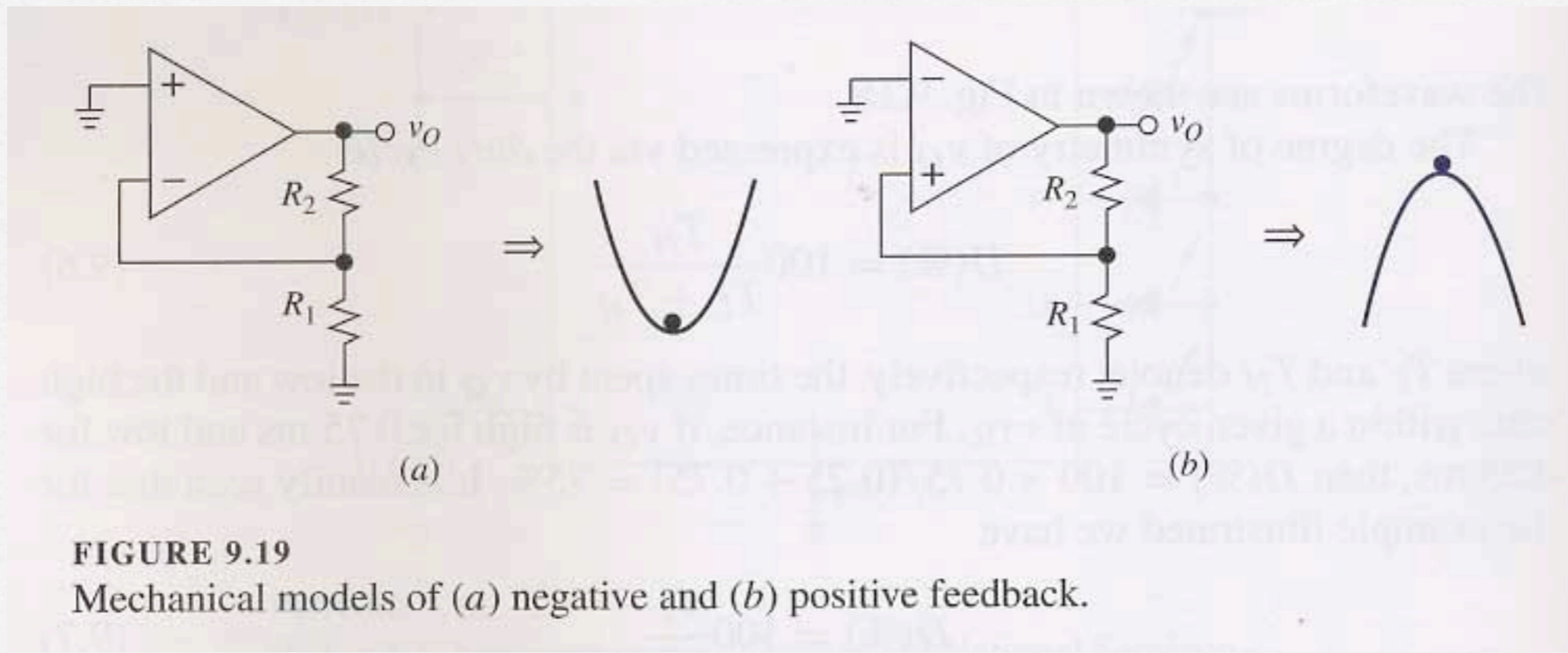
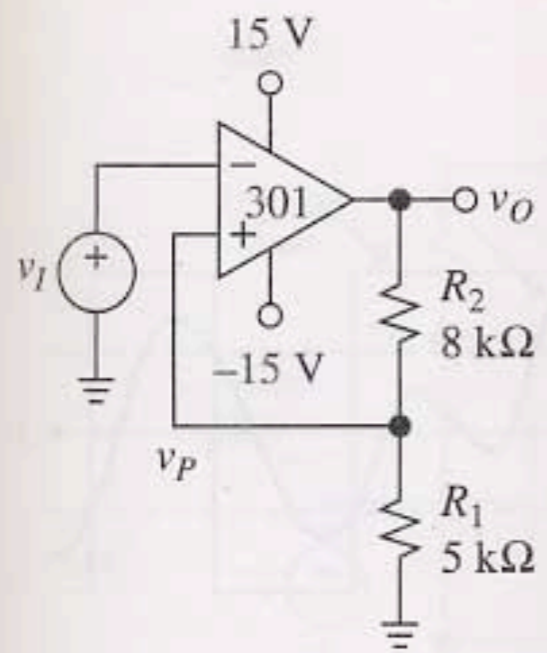
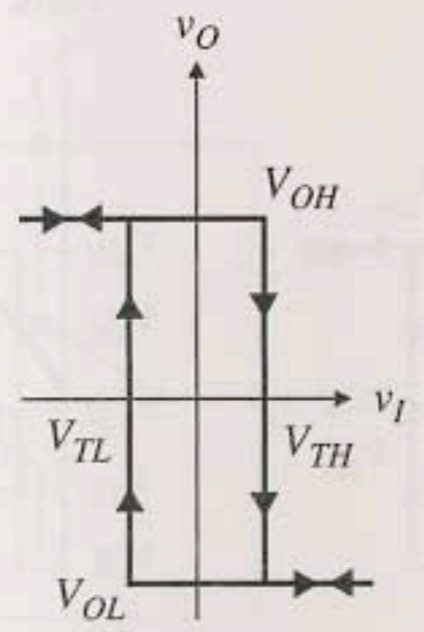

FIGURE 9.19
 Mechanical models of (a) negative and (b) positive feedback.



(a)



(b)

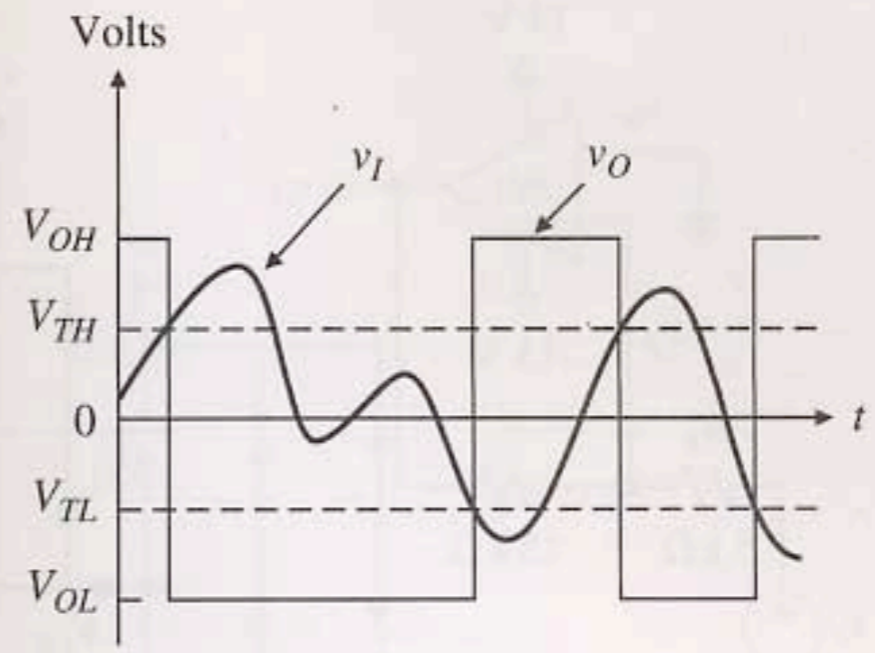

(c)

FIGURE 9.20
Inverting Schmitt trigger, VTC, and sample waveforms.

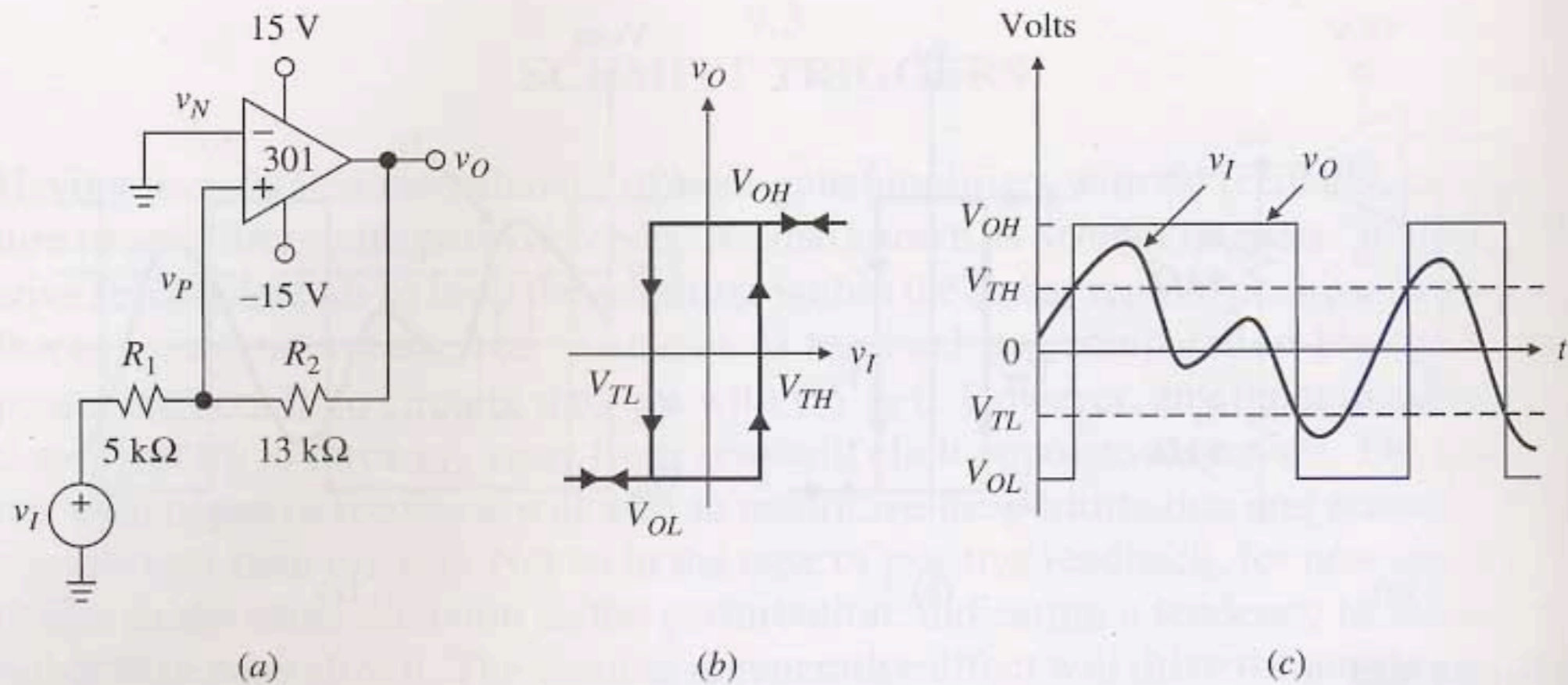

FIGURE 9.21
Noninverting Schmitt trigger, VTC, and sample waveforms.

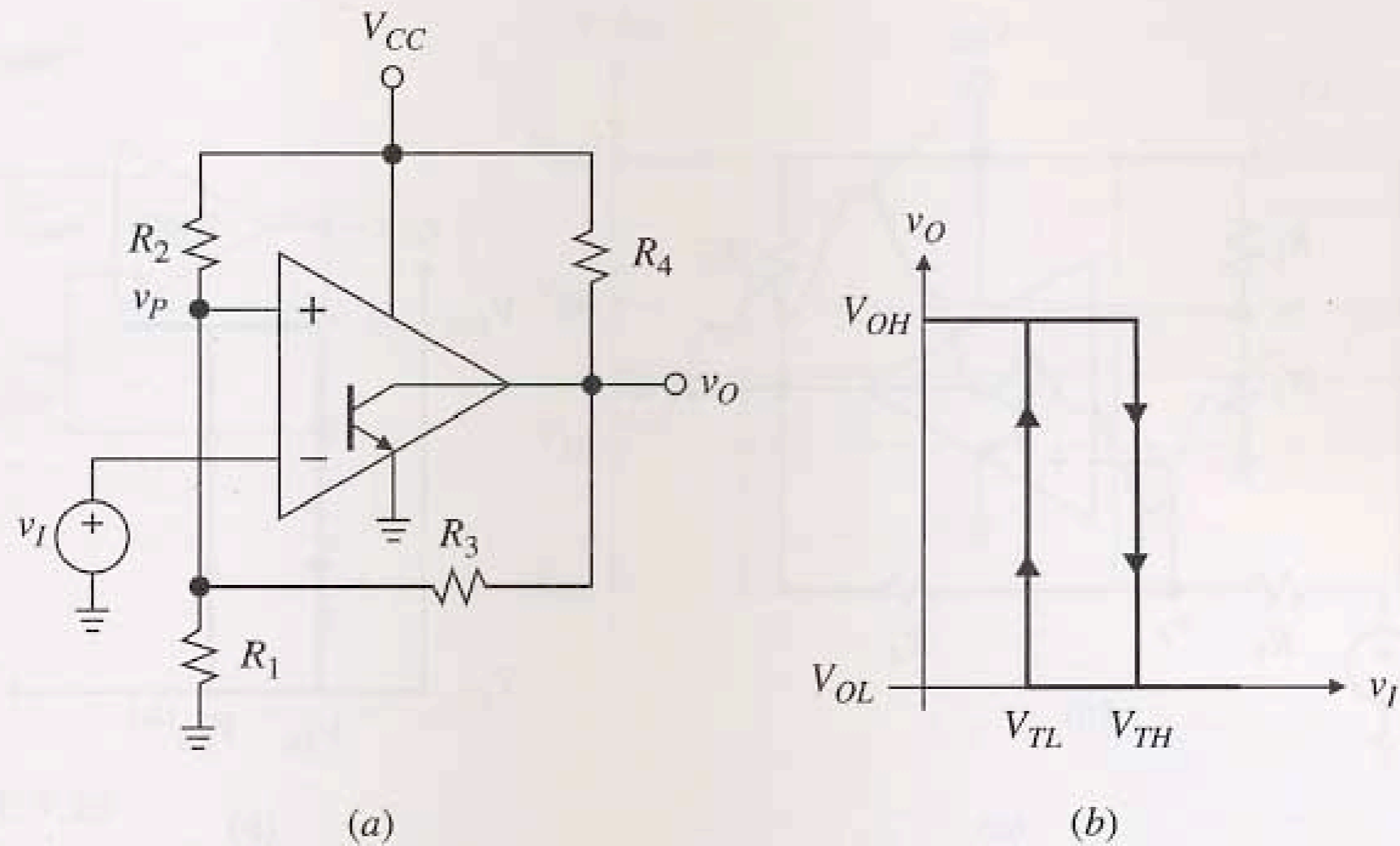
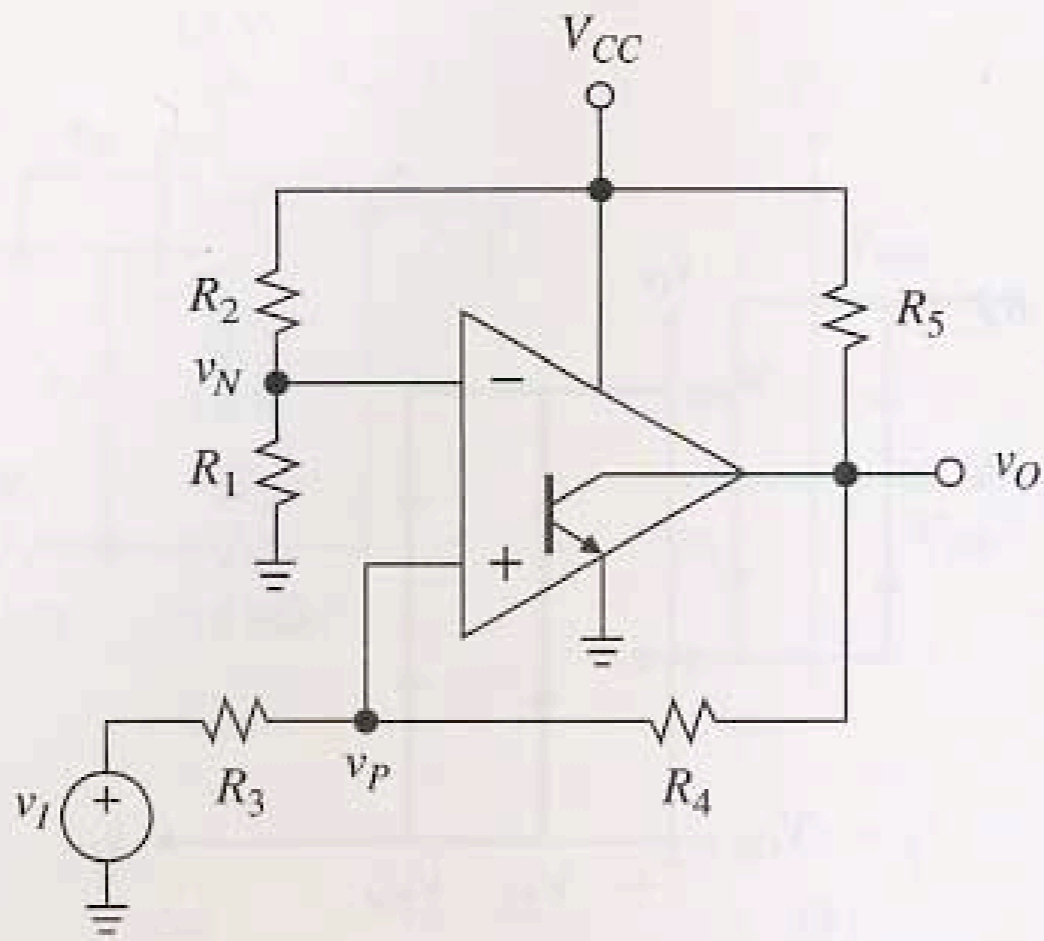
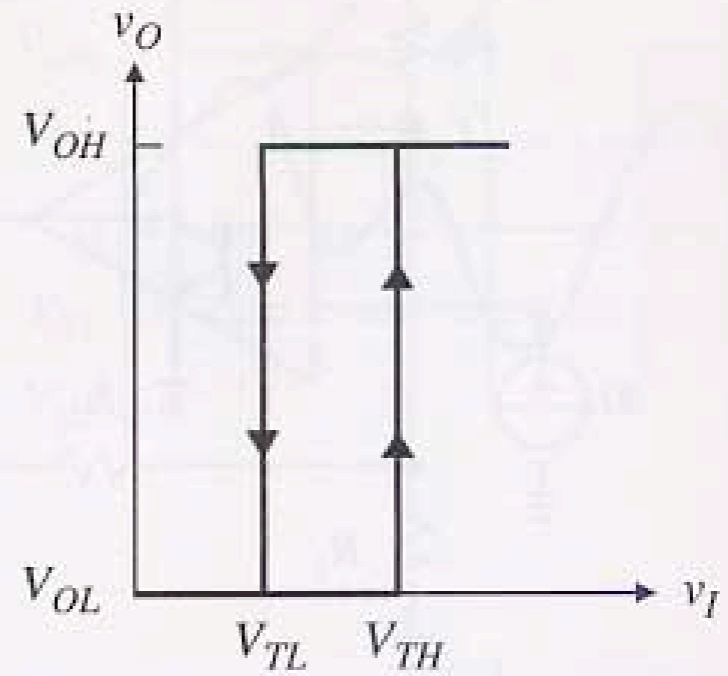

FIGURE 9.22
Single-supply inverting Schmitt trigger.



(a)



(b)

FIGURE 9.23
Single-supply noninverting Schmitt trigger.

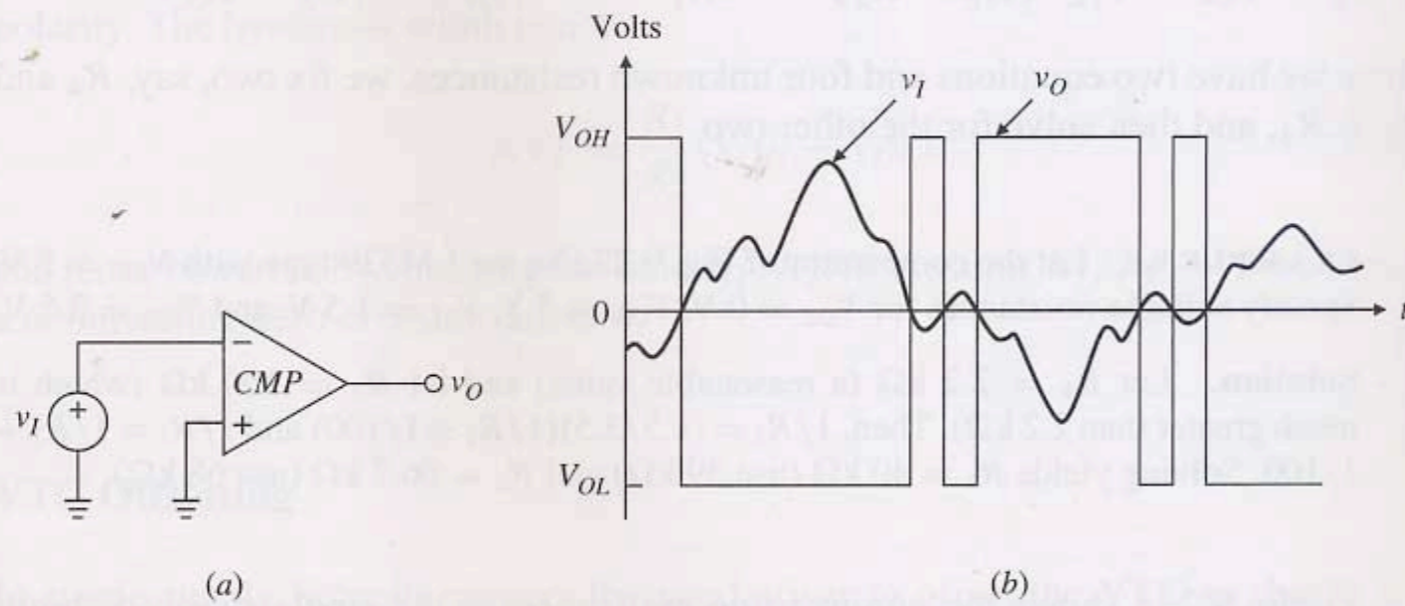

FIGURE 9.24
Comparator chatter.

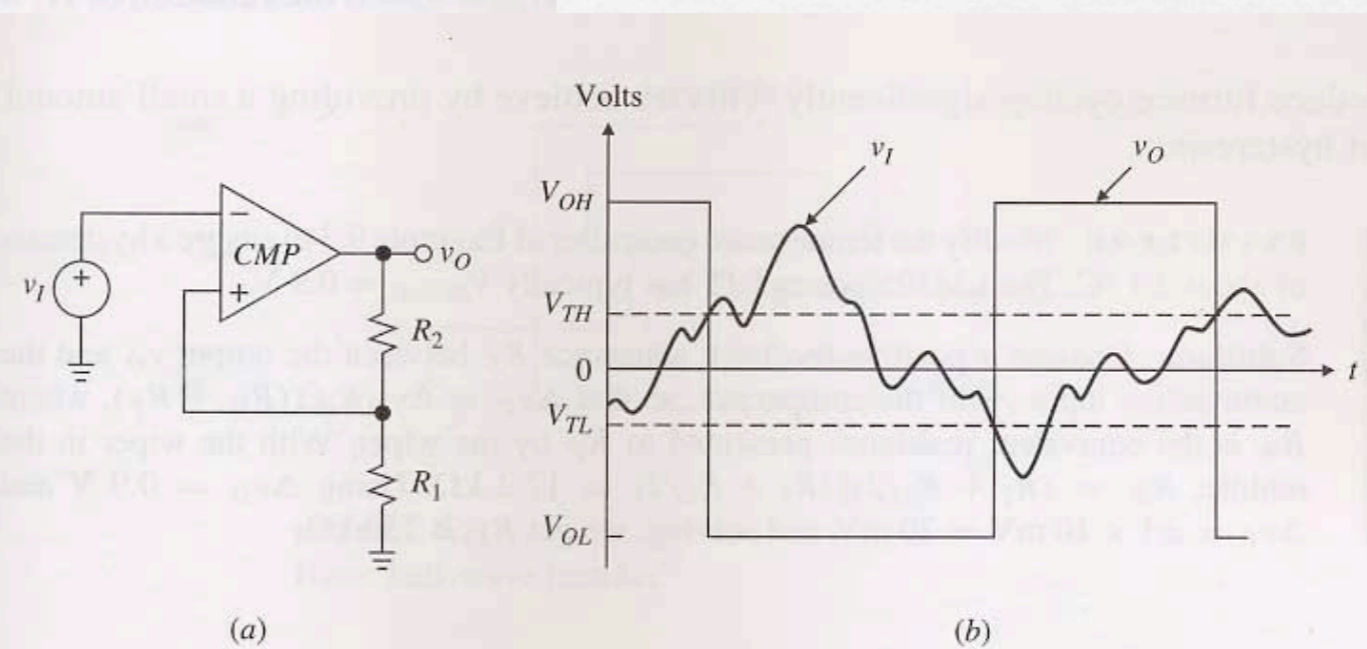

FIGURE 9.25
Using hysteresis to eliminate chatter.

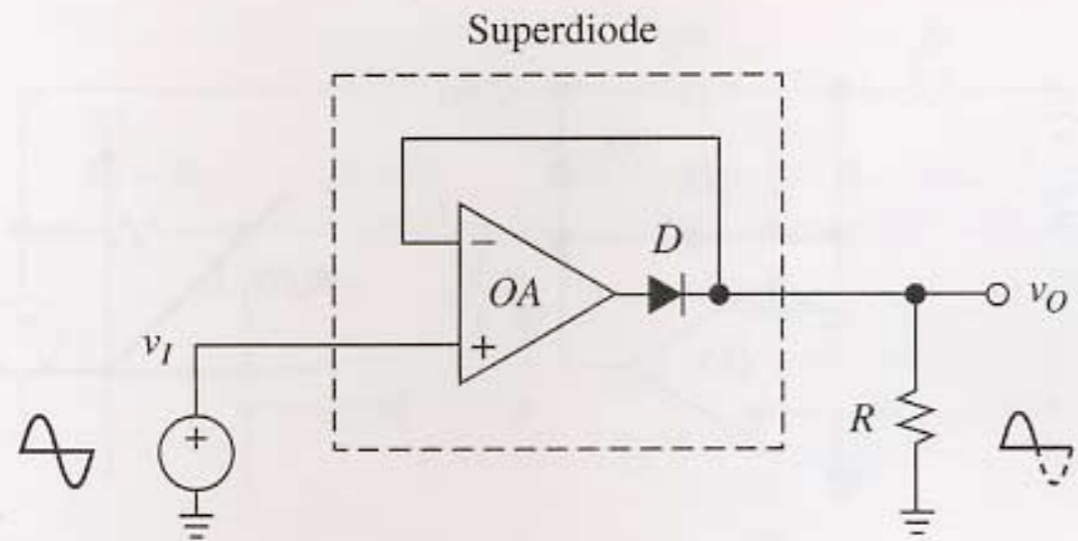

FIGURE 9.27
Basic half-wave rectifier.

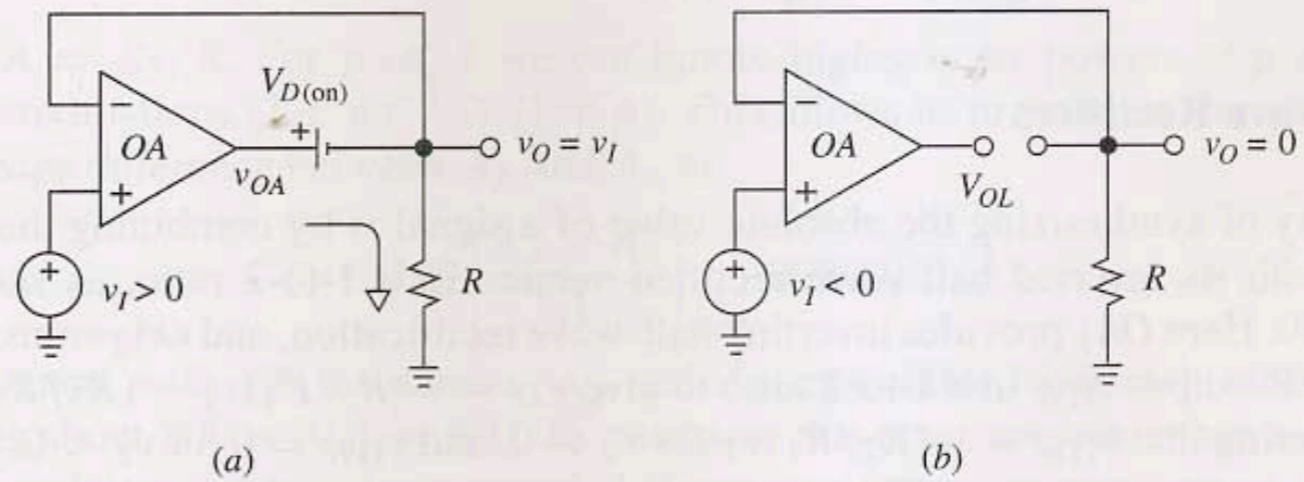

FIGURE 9.28
Equivalent circuits of the basic HWR for (a) positive and (b) negative inputs.

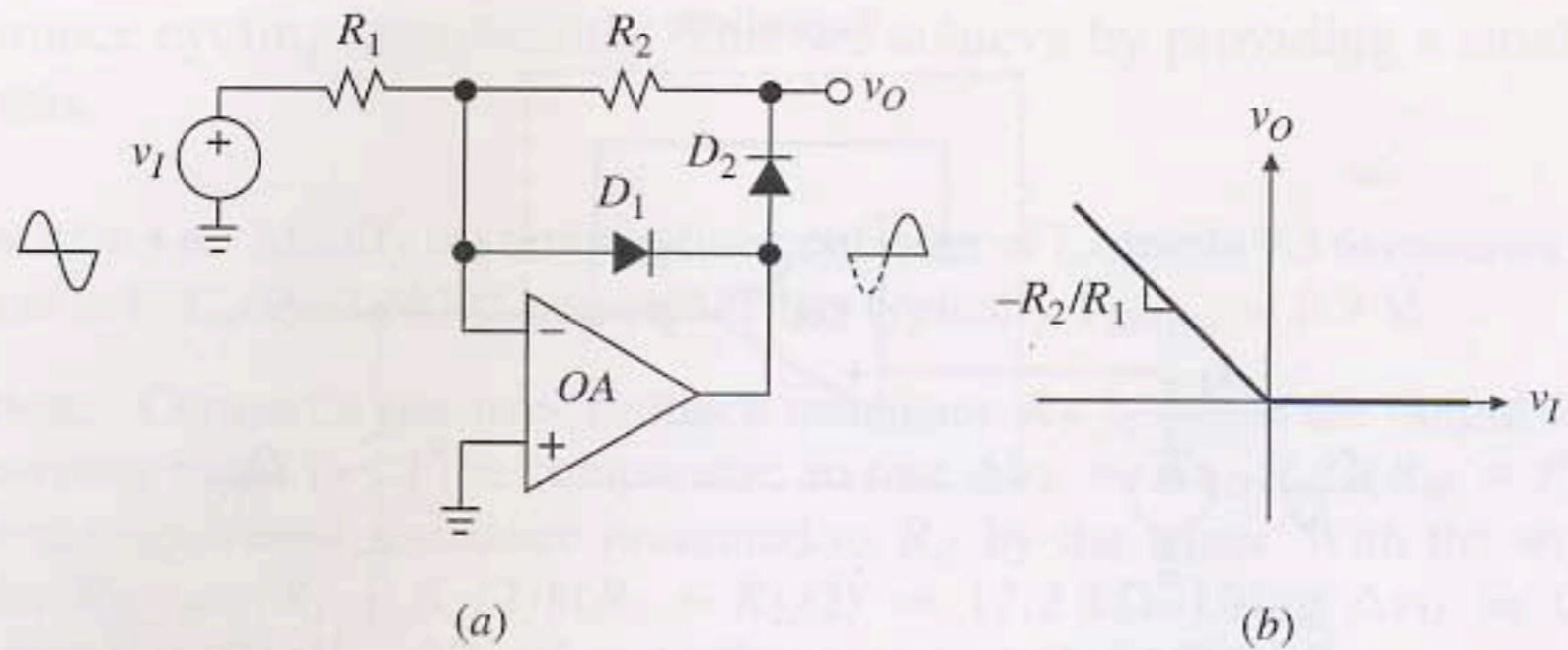

FIGURE 9.29
Improved HWR and its VTC.

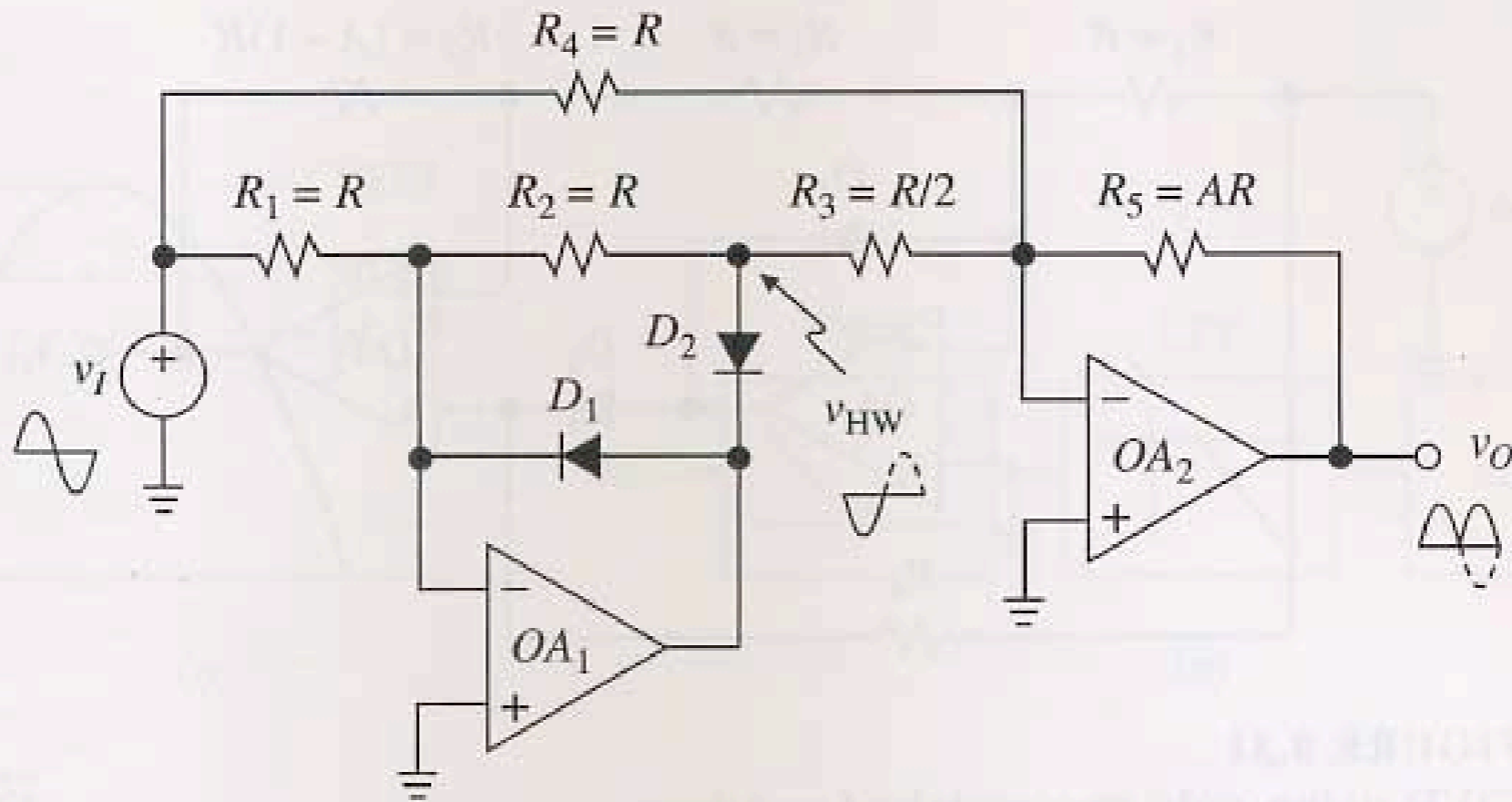

FIGURE 9.30
Precision FWR, or absolute-value circuit.

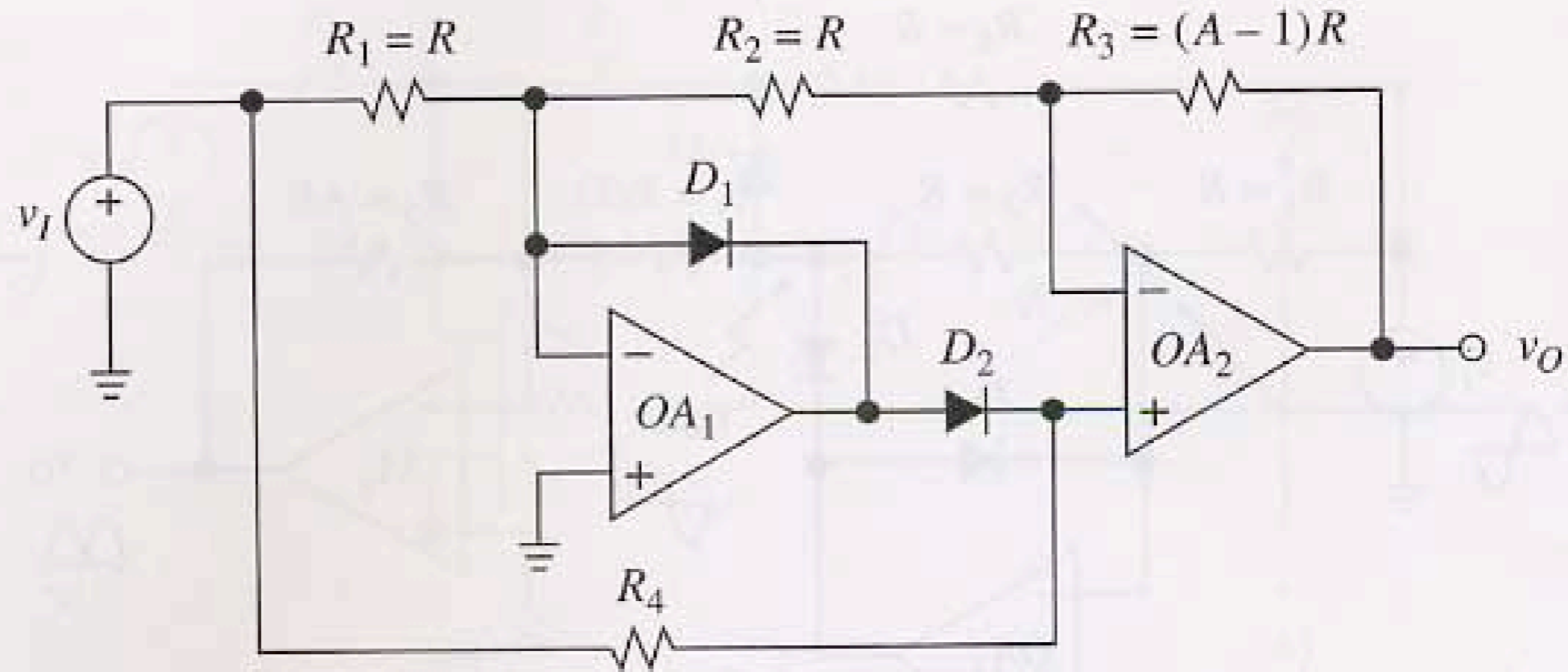

FIGURE 9.31
FWR using only two matched resistors.

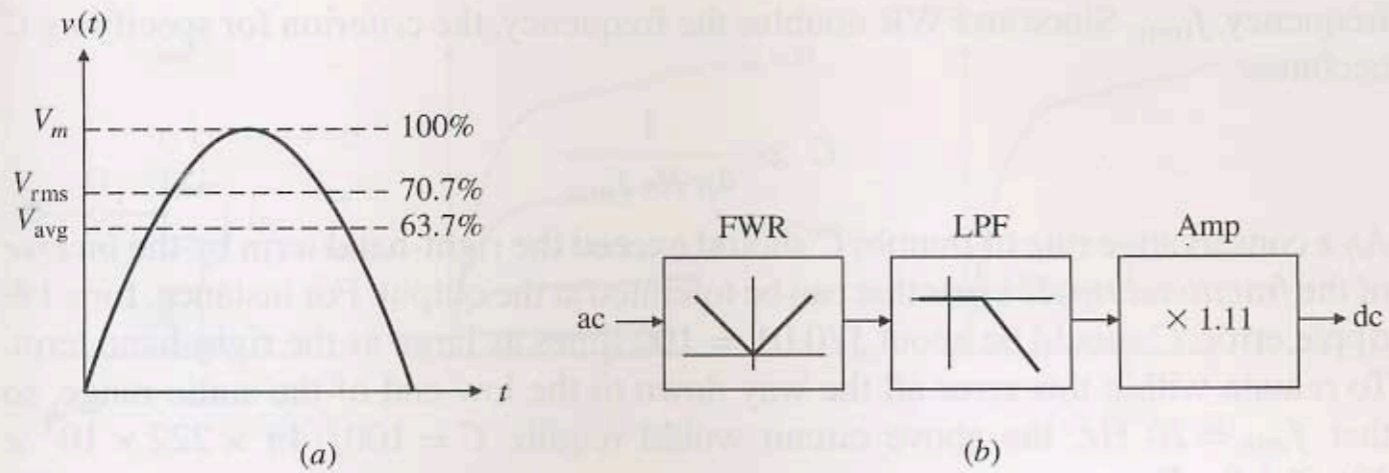

FIGURE 9.32
 (a) Relationship between V_{rms} and V_m , and between V_{avg} and V_m . (b) Block diagram of an ac-dc converter.

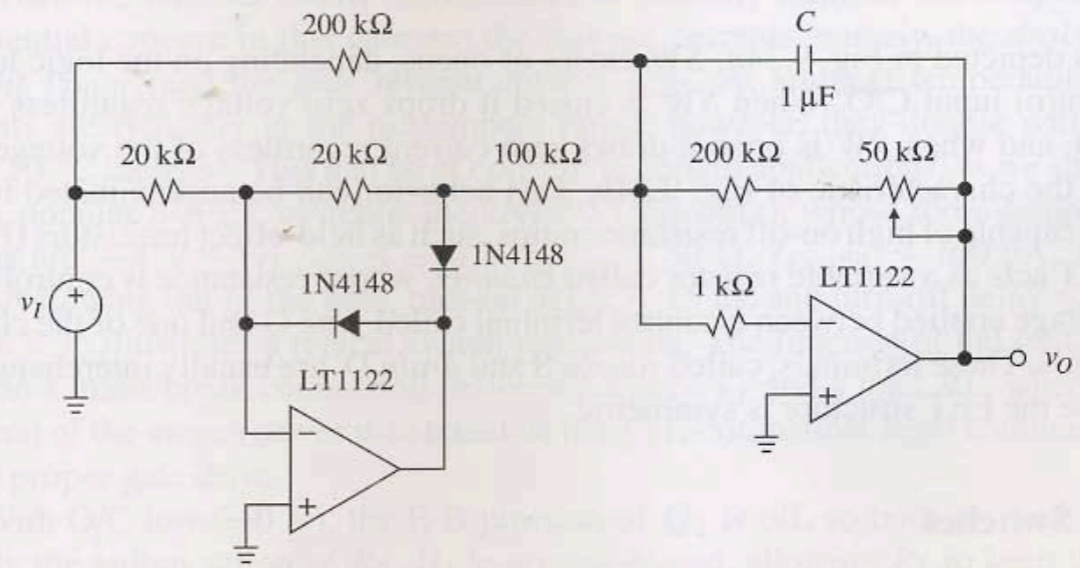

FIGURE 9.33
 Wideband ac-dc converter.