

Current-feedback amplifiers (CFA)

INEL 5207 - Spring 2010

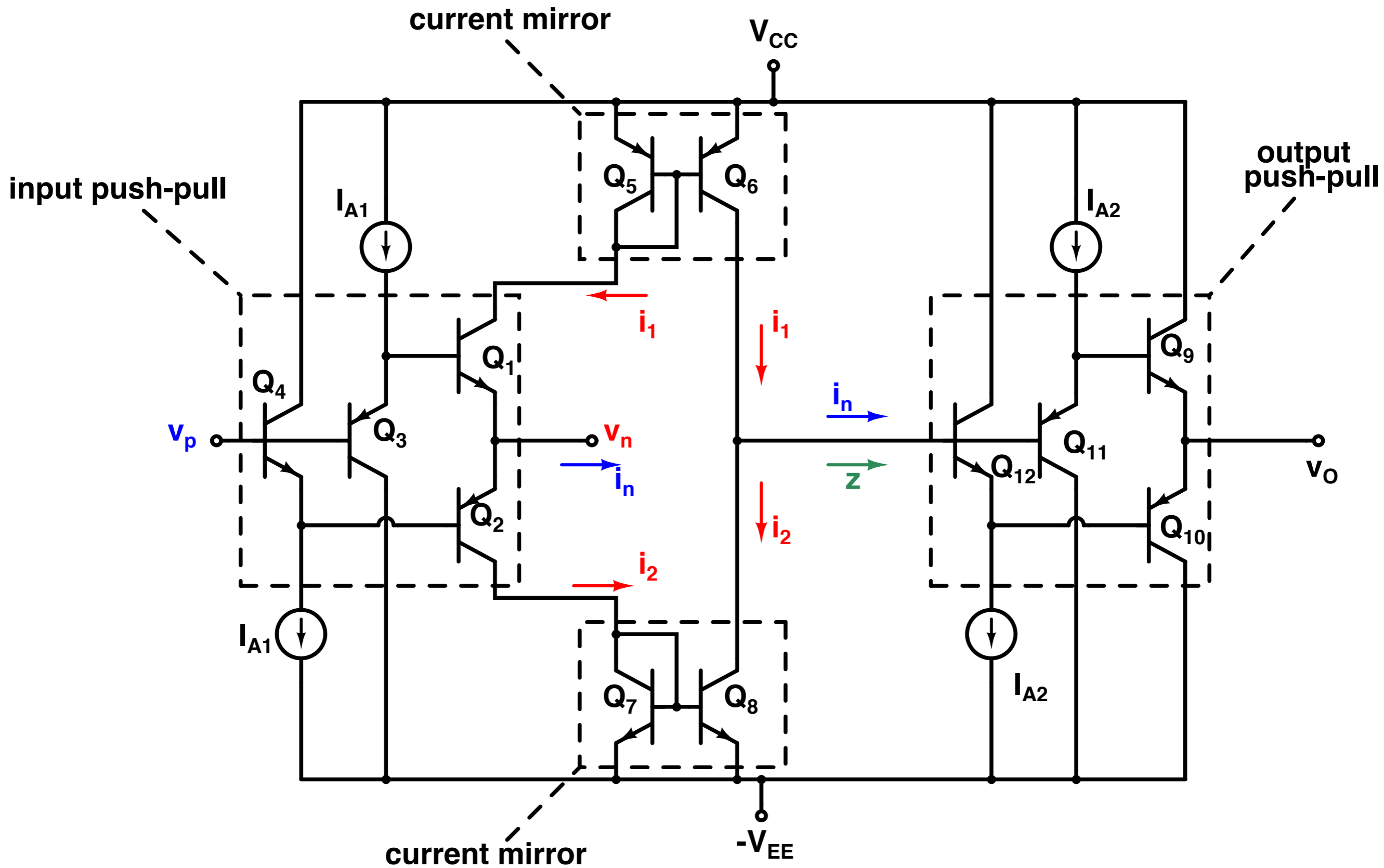

- input buffer forces v_n to track v_p
- v_p : high input impedance and low bias current
- v_n : low output impedance and high current sourcing/sinking capability
- $i_n \approx 0$ during quiescent operation (only error current)
- i_n is mirrored into the output section
- $v_{OUT} = z \times i_n$
- z is the *transimpedance gain* (like open-loop gain in VFA)

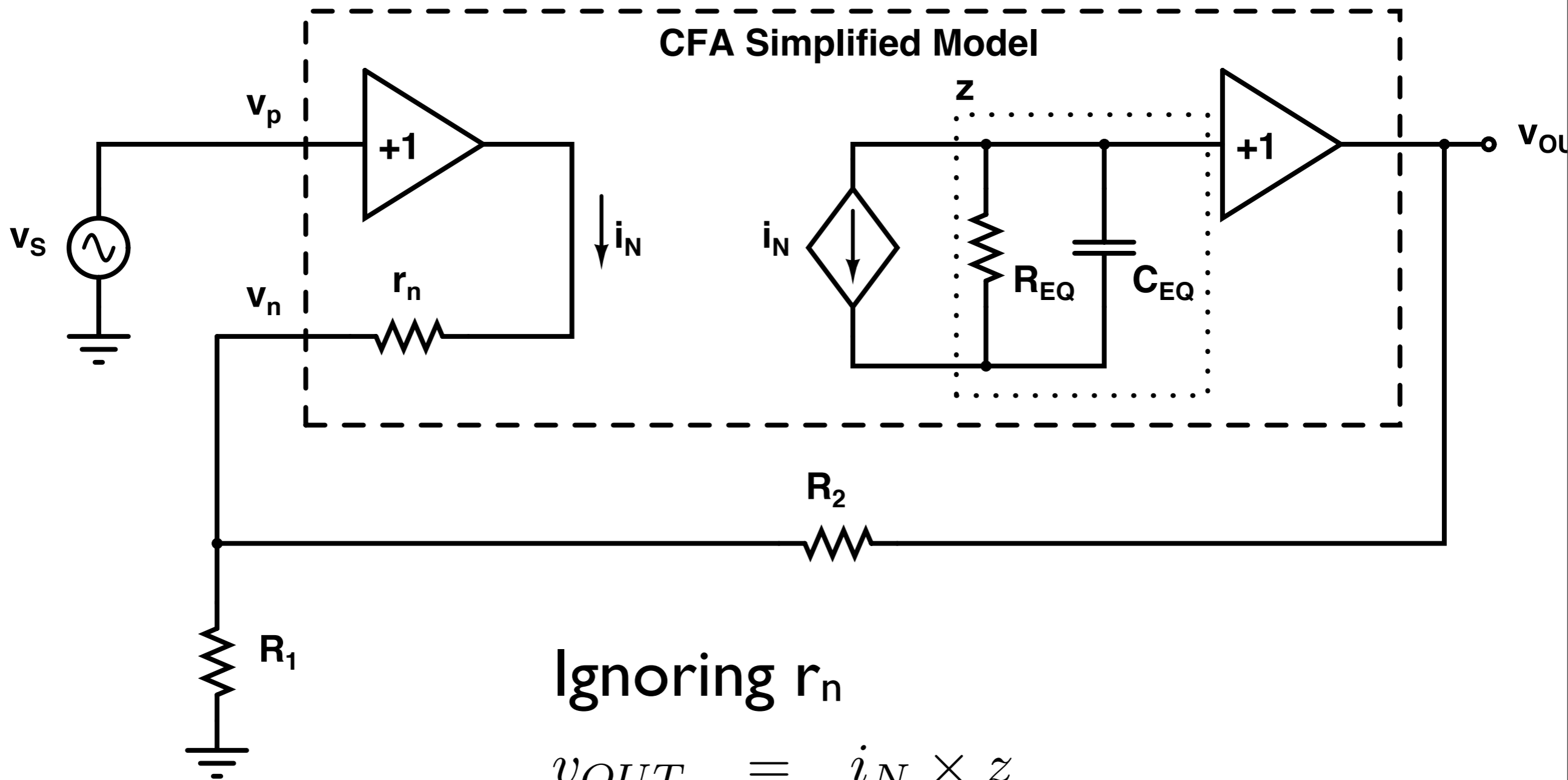

Ignoring r_n

$$v_{OUT} = i_N \times z$$

$$i_N = v_{OUT} / z$$

$$= \frac{v_S}{R_1} + \frac{v_S}{R_2} - \frac{v_{out}}{R_2}$$

$$v_S \left(\frac{1}{R_1} + \frac{1}{R_2} \right) = \left(\frac{1}{R_2} + \frac{1}{z} \right) v_{OUT}$$

For $z \gg R_2$,

$$\begin{aligned} \frac{v_{OUT}}{v_S} &= \frac{\frac{1}{R_1} + \frac{1}{R_2}}{\frac{1}{R_2} + \frac{1}{z}} \\ &= \left(1 + \frac{R_2}{R_1} \right) \frac{1}{1 + \frac{R_2}{z}} \\ &= \left(1 + \frac{R_2}{R_1} \right) \frac{1}{1 + \frac{1}{T}} \\ &\approx 1 + \frac{R_2}{R_1} \end{aligned}$$

$$A = \left(1 + \frac{R_2}{R_1}\right) \frac{1}{1 + \frac{R_2}{z}}$$

$$z = \frac{R_{EQ}}{1 + sR_{EQ}C_{EQ}}$$

$$A(s) = \left(1 + \frac{R_2}{R_1}\right) \frac{1}{1 + \frac{R_2}{R_{EQ}} + sR_2C_{EQ}}$$

$$\approx A_0 \frac{1}{1 + sR_2C_{EQ}}$$

$$A_0 = 1 + \frac{R_2}{R_1}$$

- Select bandwidth with R_2 , gain with R_1
- Bandwidth is independent of gain
- Stability is determined by loop gain $T = a\beta = \frac{z}{R_2}$
- $a = z$
- $\beta = \frac{1}{R_2}$
 - R_2 should never be zero since then $a\beta \rightarrow \infty$
 - R_2 is key for stability
 - typical optimal value $R_2 \approx 1k\Omega$.
- Step response $\tau = R_2 C_{eq}$

Taking r_n into account:

$$R_2 \rightarrow R_2 (1 + r_n / (R_1 || R_2))$$

$$\rightarrow R_2 + r_n (1 + R_2 / R_1) = \frac{1}{\beta}$$

$$f_t = \frac{1}{2\pi R_2 C_{eq}}$$

$$f_B = \frac{f_t}{1 + r_n / (R_1 || R_2)}$$
$$= \frac{1}{2\pi C_{eq} (R_2 + r_n (1 + R_2 / R_1))}$$

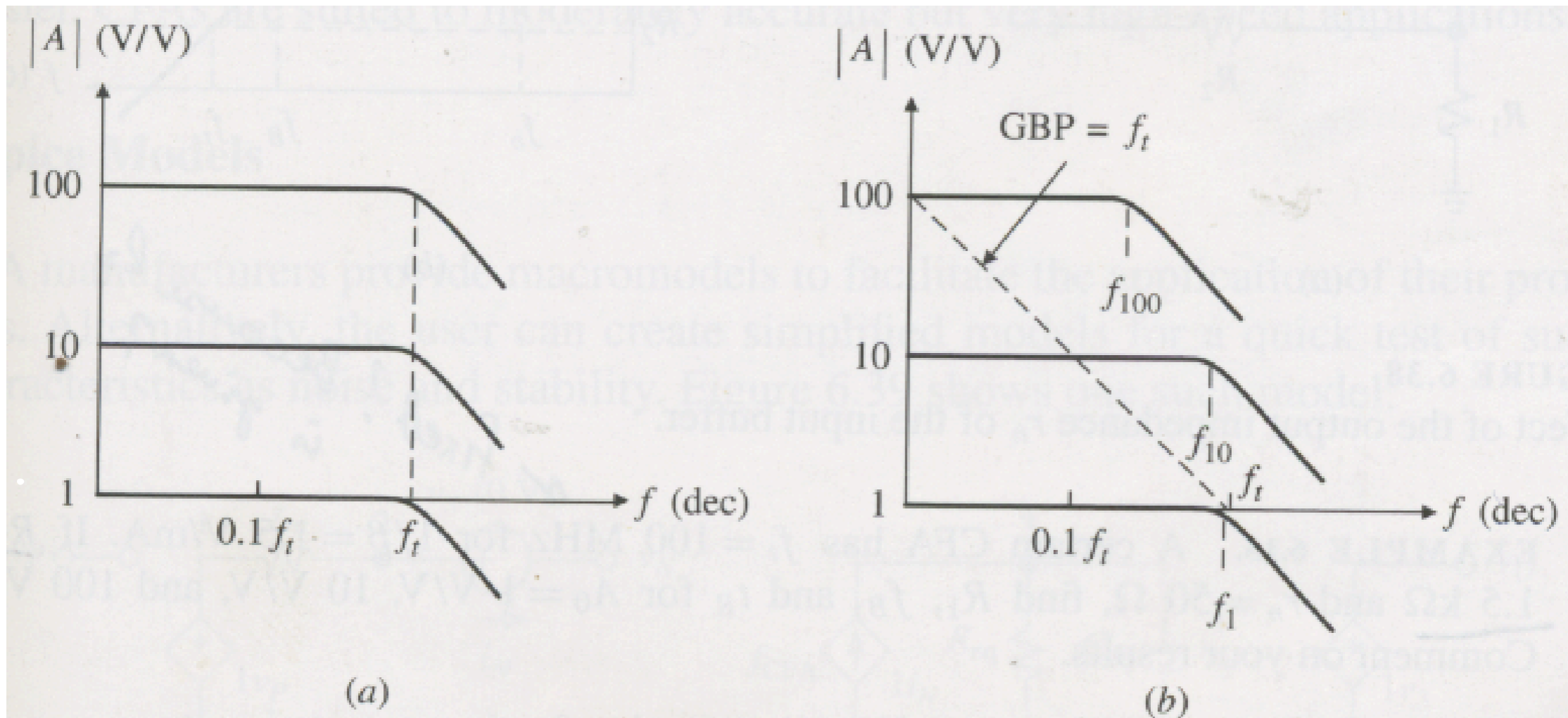

FIGURE 6.37

Closed-loop bandwidth as a function of gain for (a) an ideal CFA and (b) a practical CFA.

Inverting configuration is also possible; $A_0 = -R_2/R_1$

CFA versus VFA

- Disadvantages

- poorer V_{OS}
- poorer I_B
- noisier
- lower open-loop gain

- Advantages

- faster
- Conclusion: CFA are suited for moderately accurate high-speed apps.

Prob. 6.57

Assume a CFA with $z_0=0.5\text{V}/\mu\text{A}$, $C_{\text{eq}}=1.59\text{pF}$,
 $r_n=25\Omega$, $I_P=1\mu\text{A}$, $I_N=2\mu\text{A}$, $(1/\beta)_{\text{min}}=1\text{V}/\text{mA}$,
 $V_{\text{OS}}=1\text{mV}$.

(a) Design an amplifier with $A_0 = -2\text{V}/\text{V}$ and maximum bandwidth. What is the bandwidth and the loop gain?

(b) Repeat for $A_0 = -10\text{V}/\text{V}$.

(c) Repeat for a difference amplifier with $A_0= 1\text{V}/\text{V}$