

V-I & I-V CONVERTERS

INEL 5205 Instrumentation

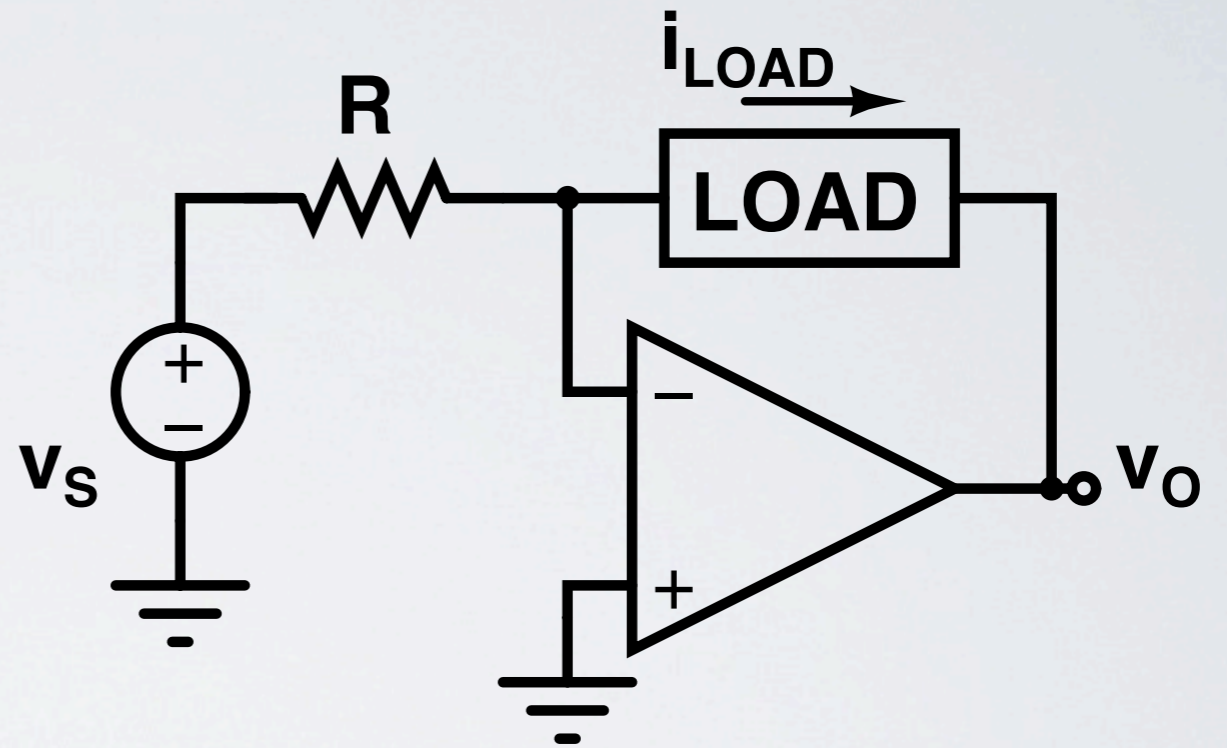

Simple V-to-I Converter

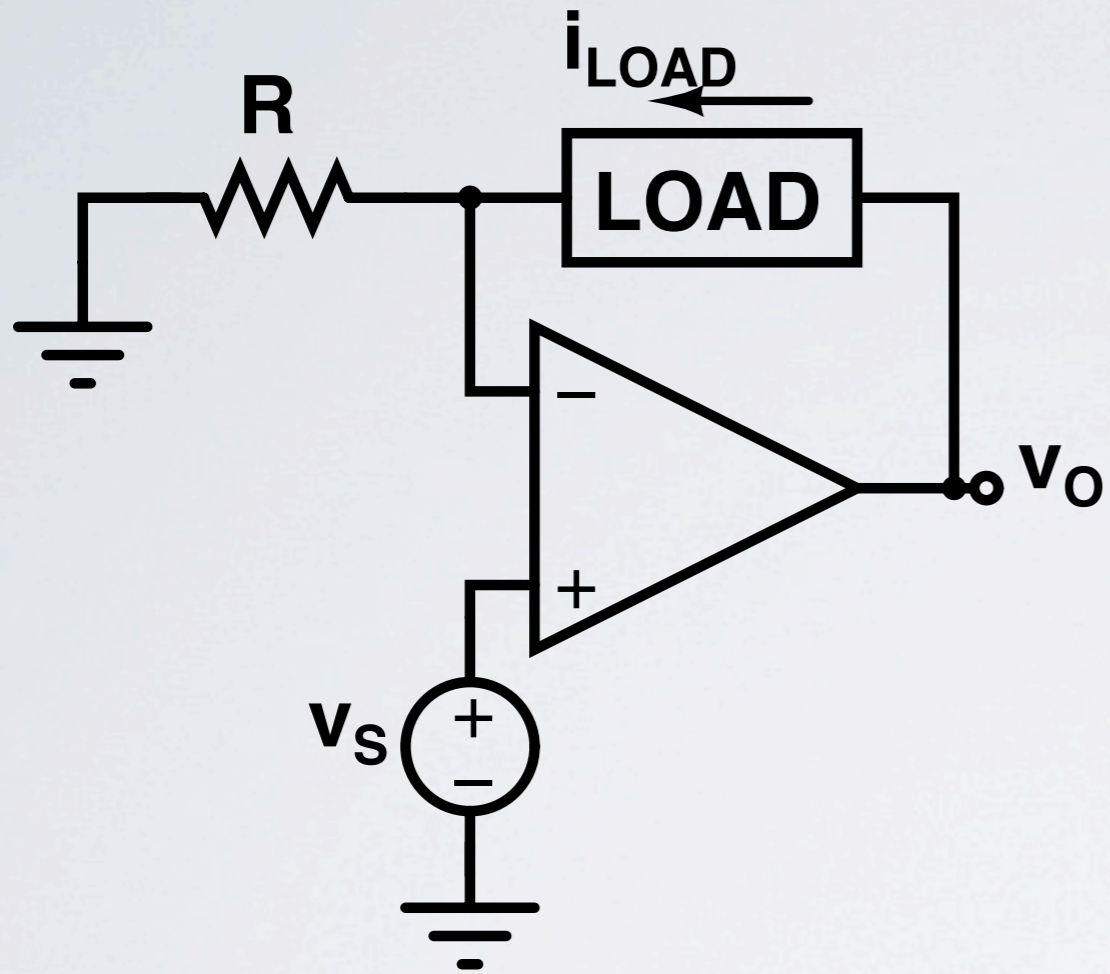
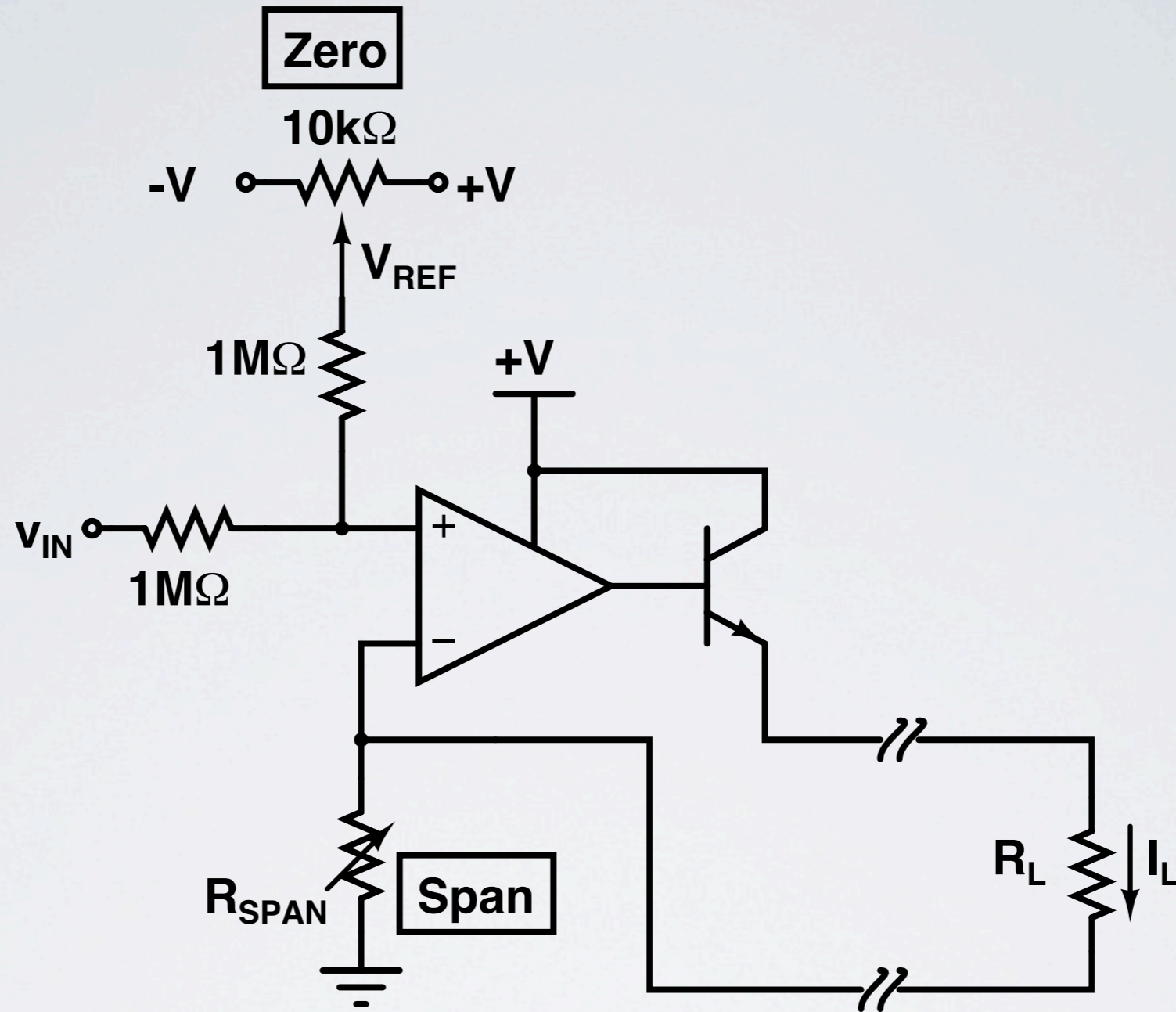

Example: Select R_{SPAN} and V_{REF} so that $I_L = 4\text{mA}$ for $V_{IN} = -5\text{V}$ and 20mA for $V_{IN} = +10\text{V}$

- Keep in mind:
 - Avoid opamp saturation
 - Use current boosting if $i_{\text{LOAD}} > i_{\text{SC}}$

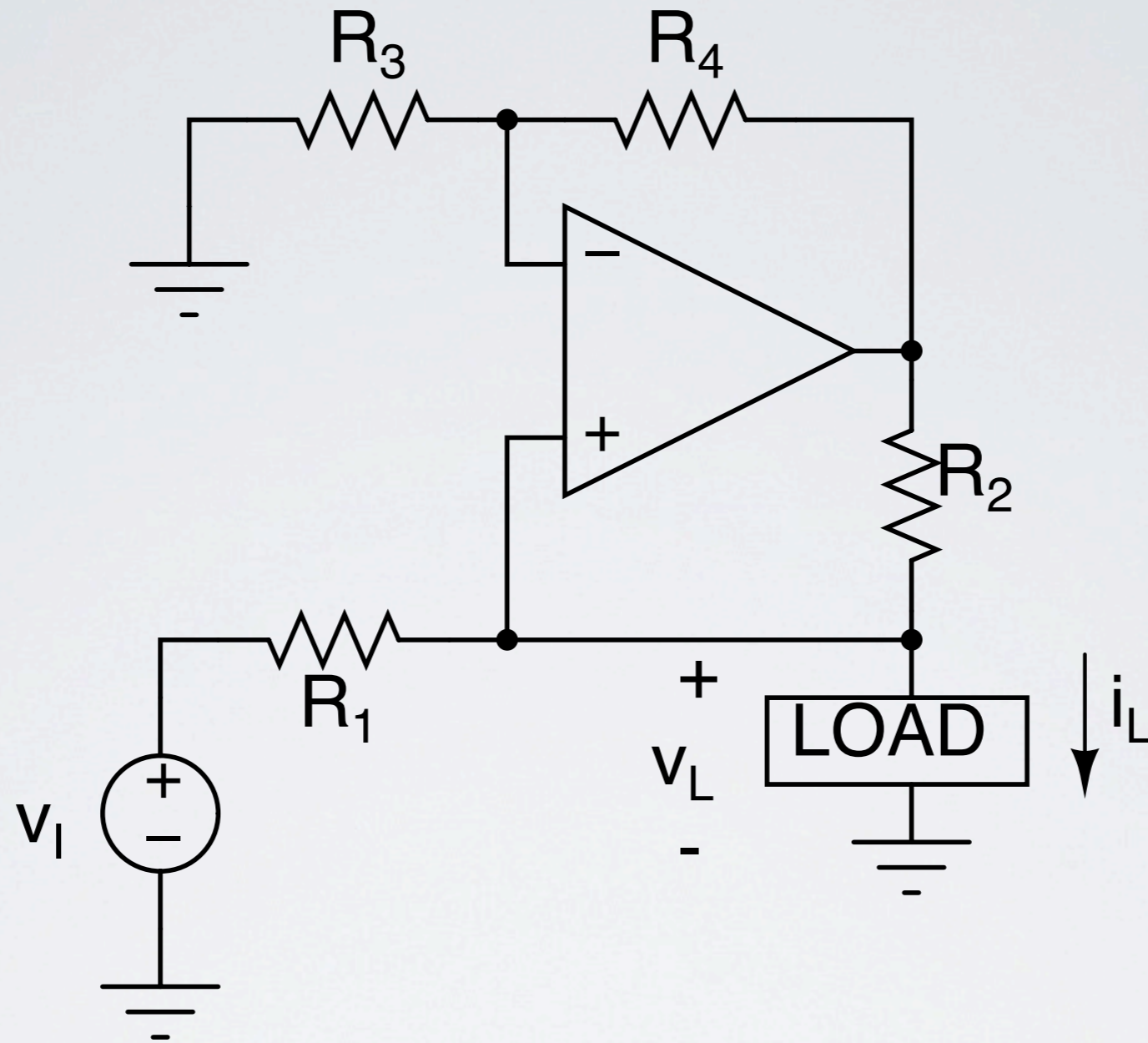

$$\text{If } \frac{R_2}{R_1} = \frac{R_4}{R_3}, i_L = \frac{v_i}{R_1}$$

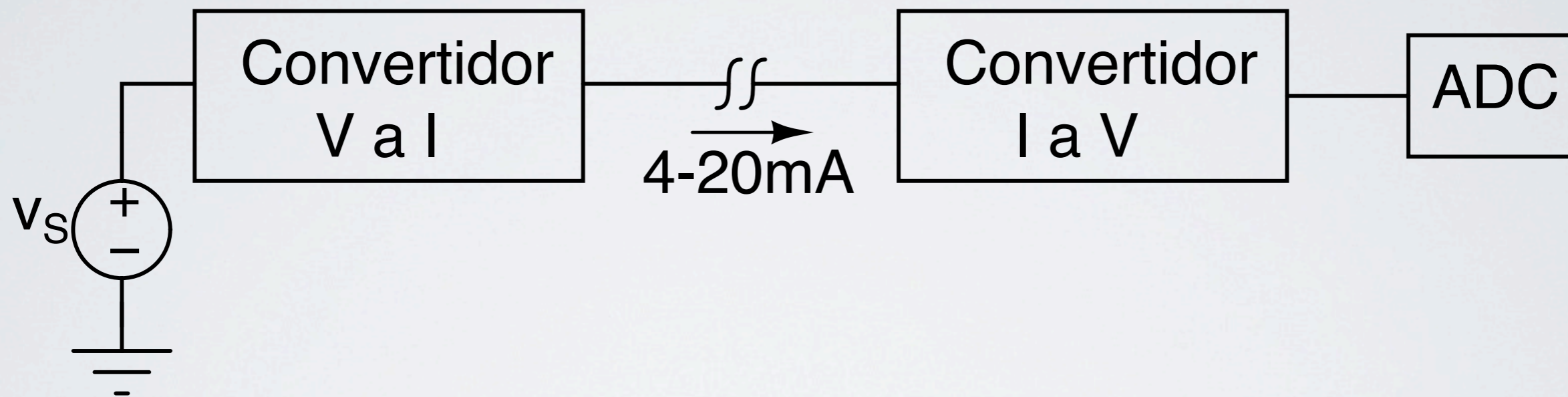

XTR-110 PRECISION V-TO-I CONVERTER

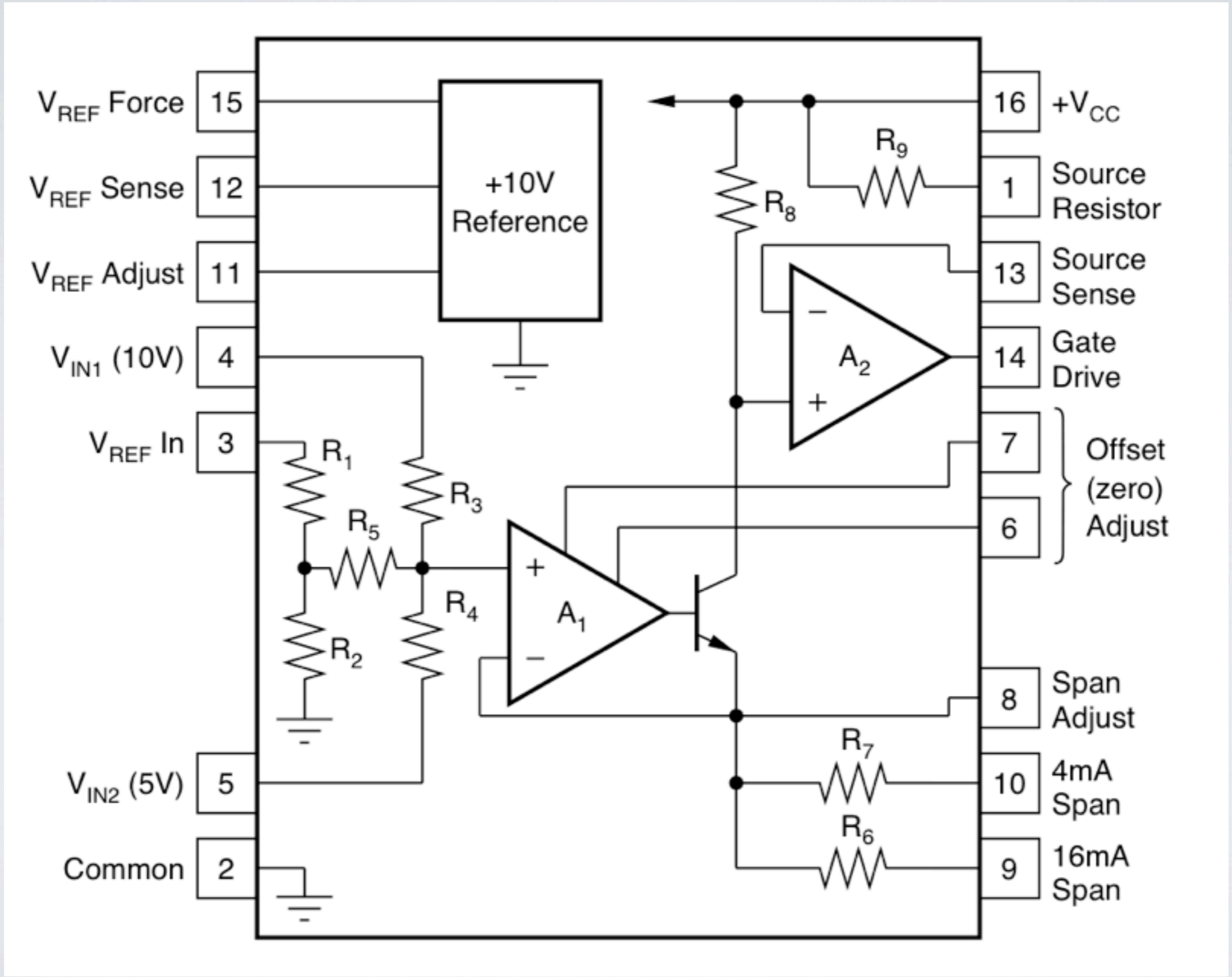

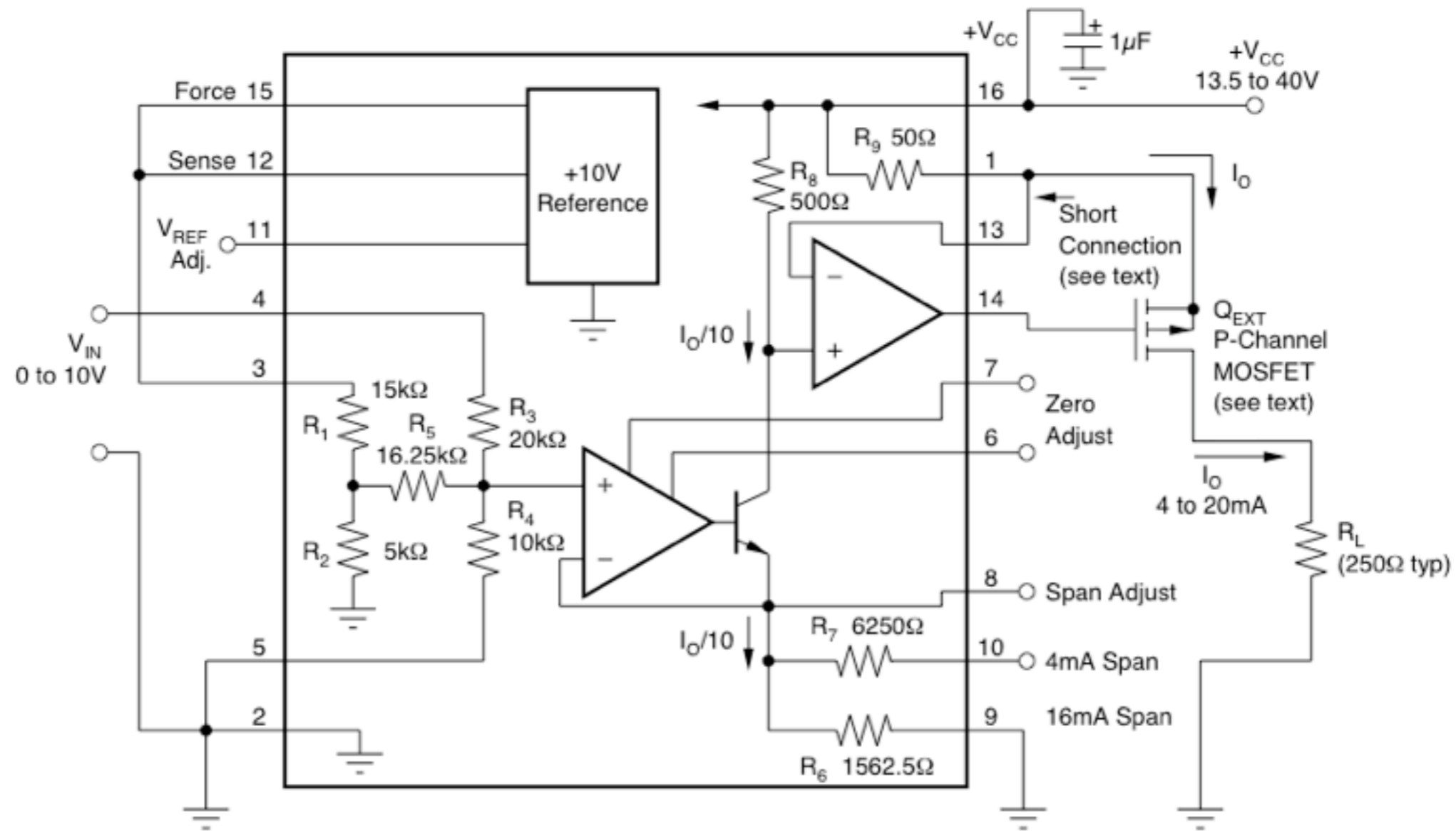

INPUT RANGE (V)	OUTPUT RANGE (mA)	PIN 3	PIN 4	PIN 5	PIN 9	PIN 10
0-10	0-20	Com	Input	Com	Com	Com
2-10	4-20	Com	Input	Com	Com	Com
0-10	4-20	+10V Ref	Input	Com	Com	Open
0-10	5-25	+10V Ref	Input	Com	Com	Com
0-5	0-20	Com	Com	Input	Com	Com
1-5	4-20	Com	Com	Input	Com	Com
0-5	4-20	+10V Ref	Com	Input	Com	Open
0-5	5-25	+10V Ref	Com	Input	Com	Com

$$I_O \simeq 10 \frac{V_{REF,in}/16 + V_{IN,1}/4 + V_{IN,2}/2}{R_{span}}$$

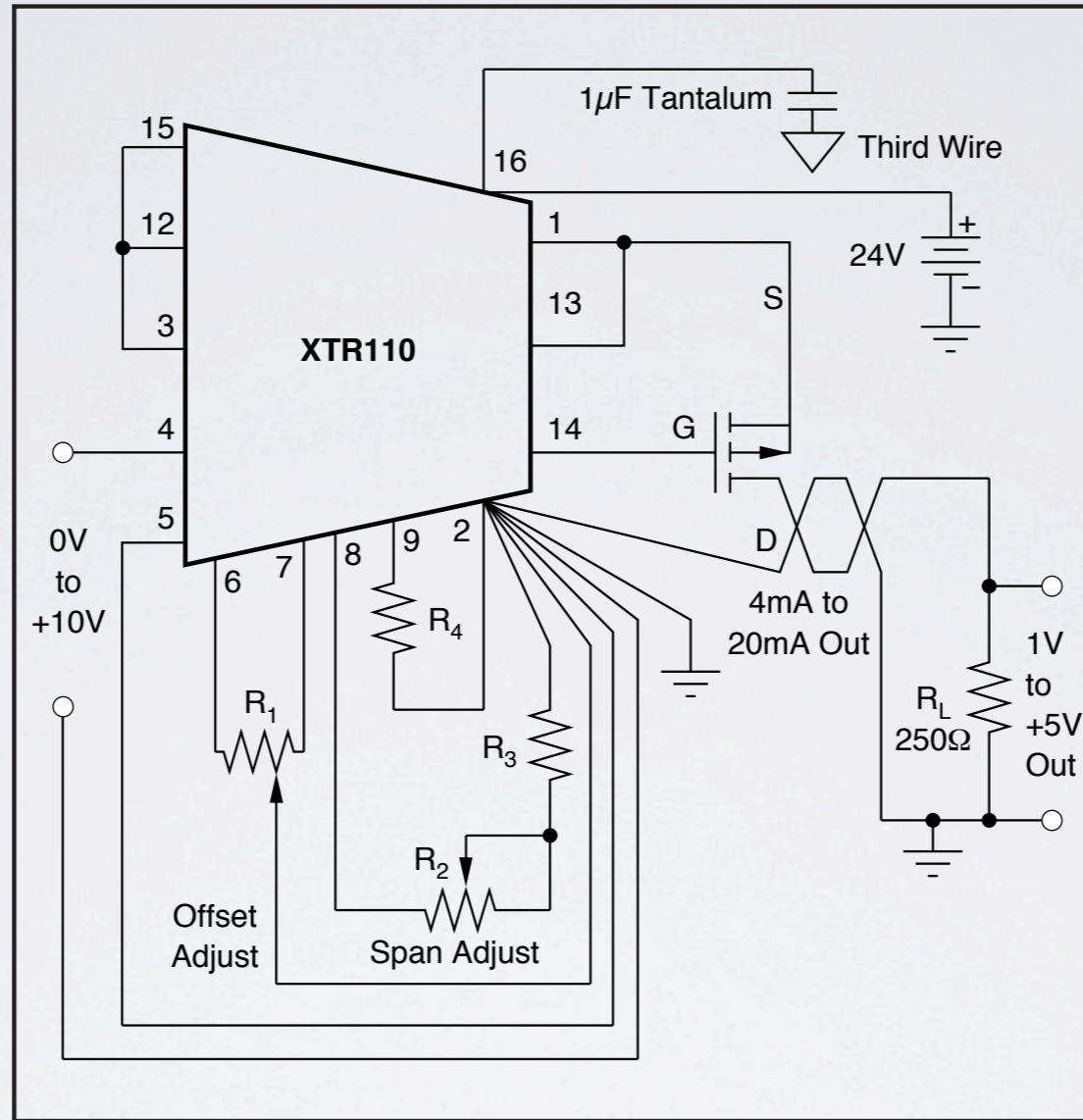

FIGURE 5. Offset and Span Adjustment Circuit for 0V to +10V Input, 4mA to 20mA Output.

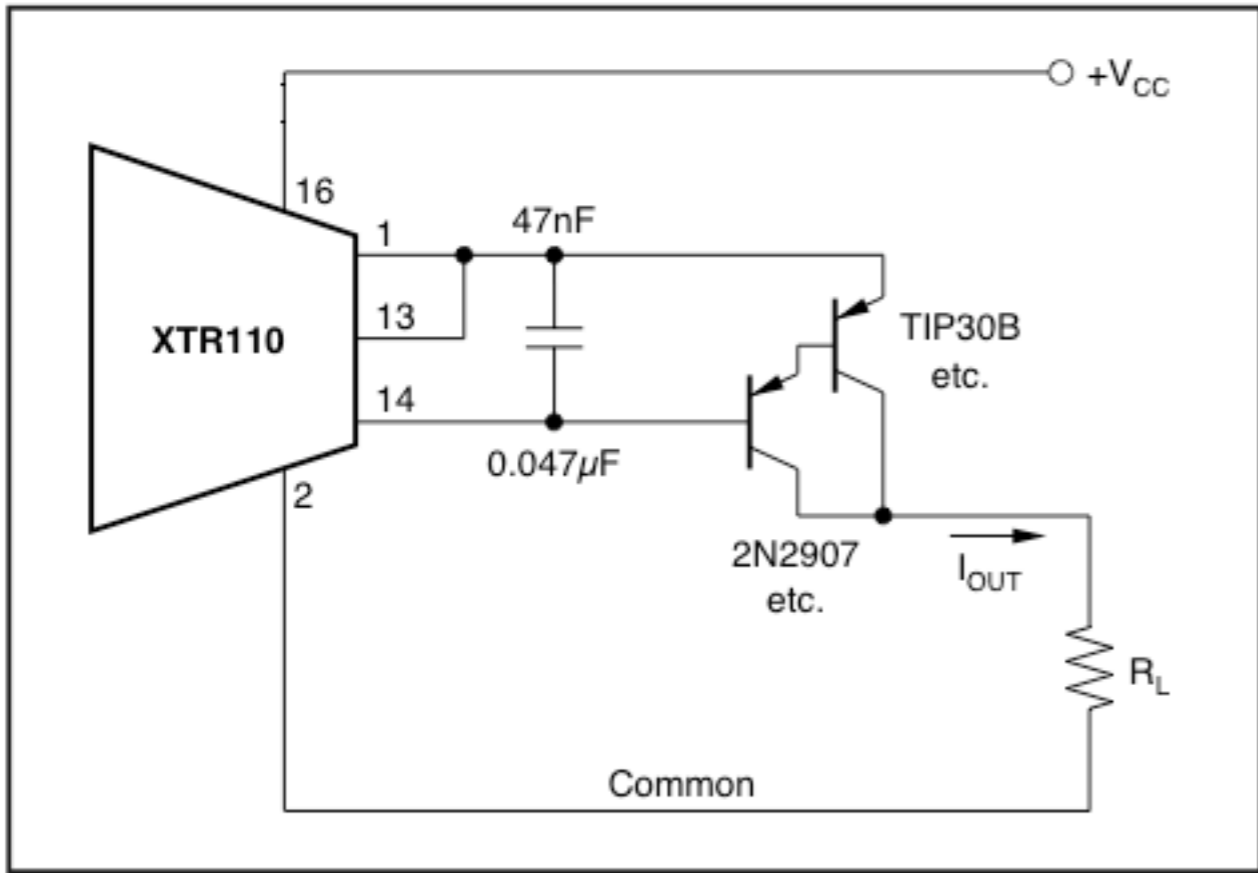
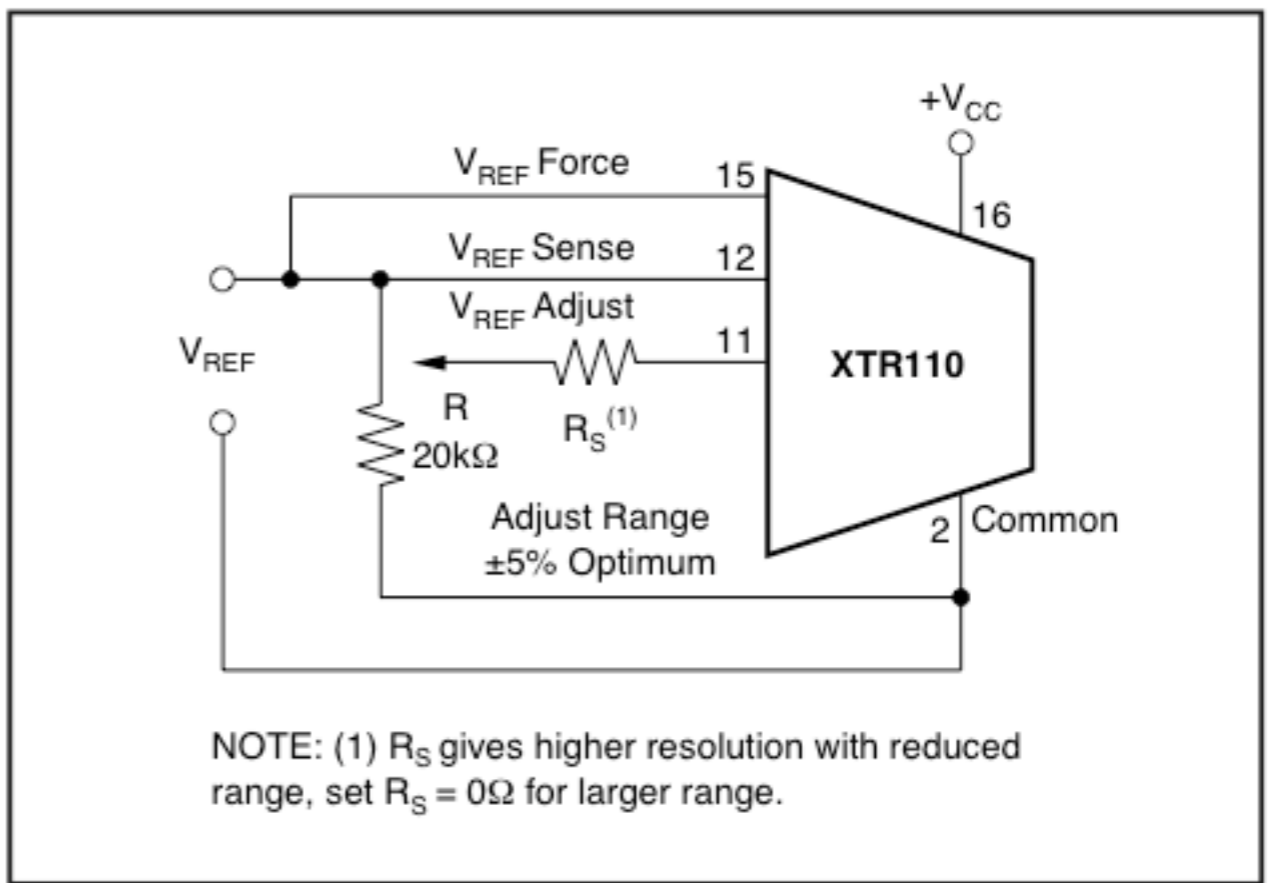

FIGURE 2. I_{EXT} Using PNP Transistors.



NOTE: (1) R_S gives higher resolution with reduced range, set $R_S = 0\Omega$ for larger range.

FIGURE 3. Optional Adjustment of Reference Voltage.

$$V_{A1} = \frac{(V_{REF IN})}{16} + \frac{(V_{IN1})}{4} + \frac{(V_{IN2})}{2}$$

V_{A1} shouldn't be below -0.5V

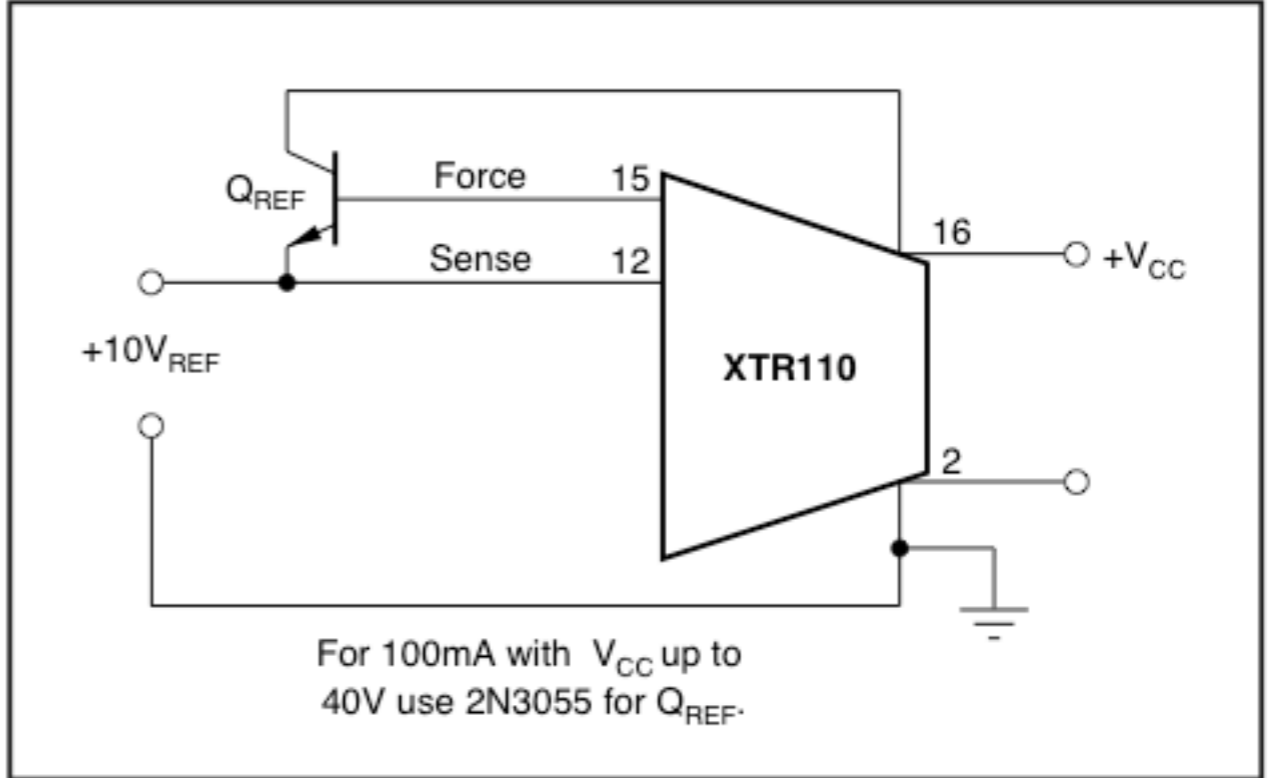

For 100mA with V_{CC} up to 40V use 2N3055 for Q_{REF} .

FIGURE 4. Increasing Reference Current Drive.

Grounded I to V converters

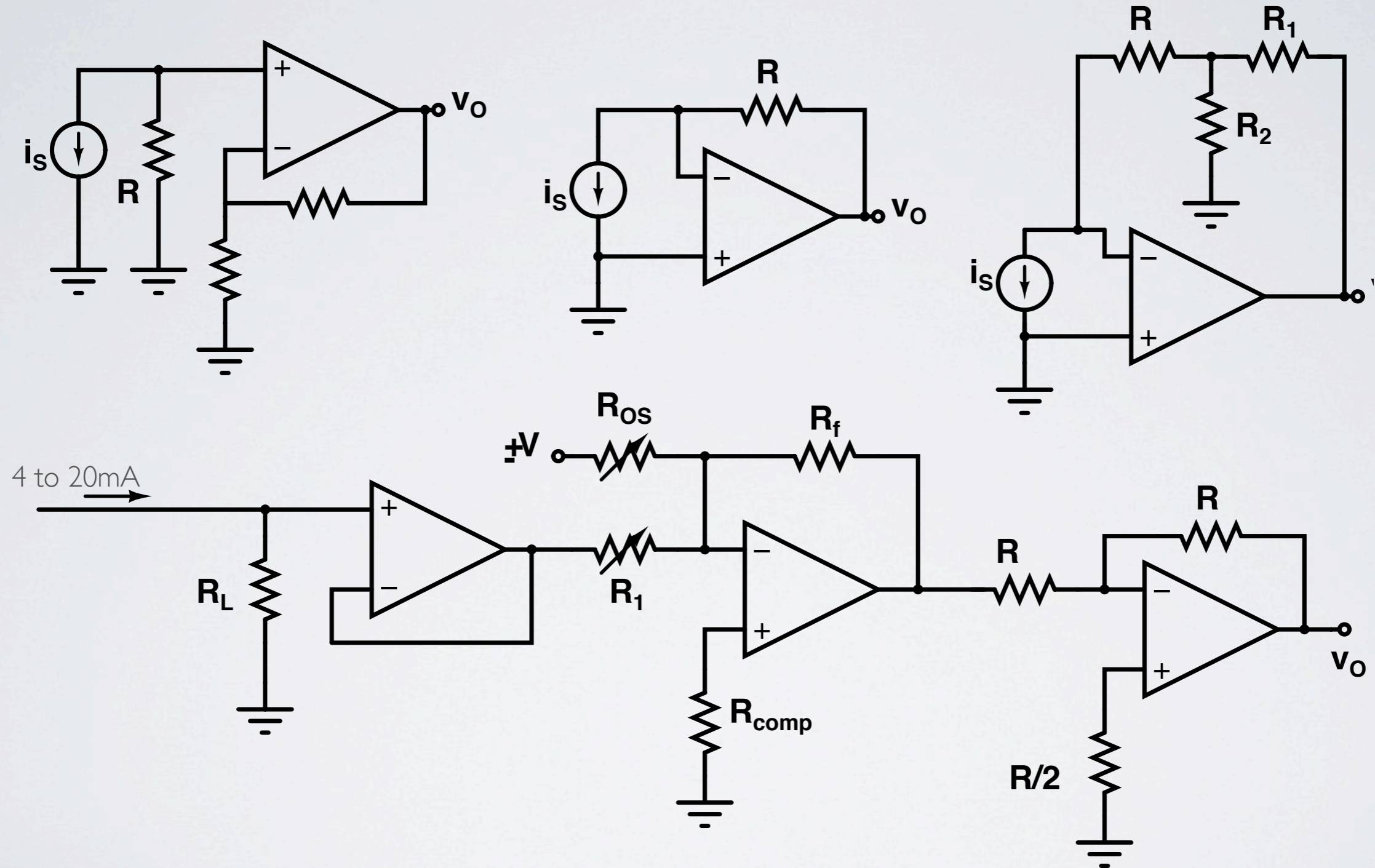

Floating I to V converter

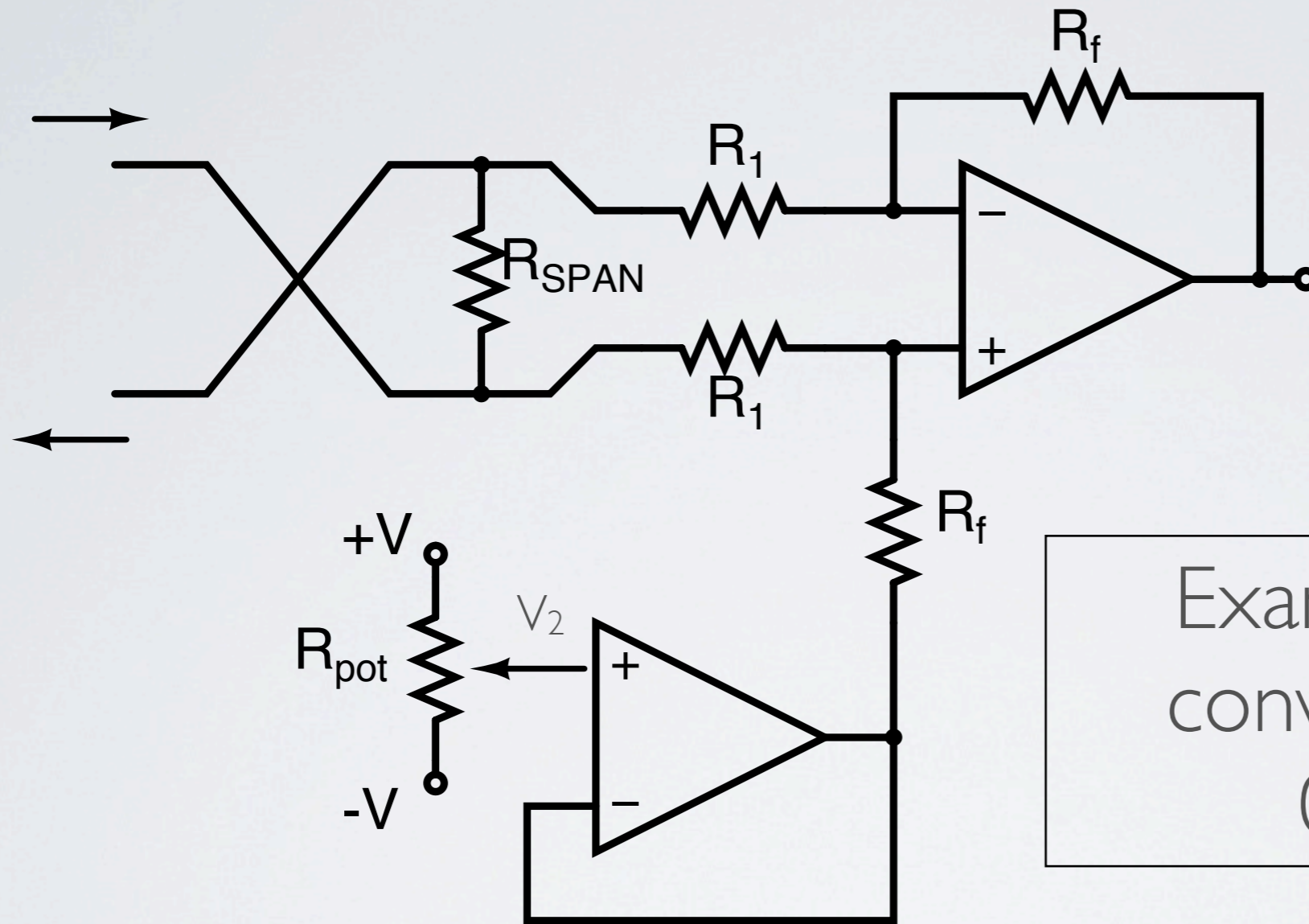

Example: Design to convert 4-20mA to 0-10V signal

$$v_{out} = \frac{R_f}{R_1} I R_{span} + V_2$$

$$R_{span} \ll R_1$$