

Circuitos Básicos con OAs

Manuel Toledo
INEL 4202

1. Introduction

El amplificador operacional (abreviado *op amp* u *OA*) es quizás el componente más importante para el diseño de circuitos analógicos. Los OA permiten la construcción de muchos circuitos de forma sencilla, con un costo bajo, y utilizando pocos componentes discretos. Una buena comprensión del uso de OAs es esencial para el desarrollo de instrumentos.

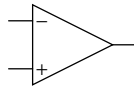

Los OAs son amplificadores diferenciales cuyo voltaje de salida es proporcional a la diferencia entre los dos voltajes de entrada. La figura superior muestra el símbolo esquemático del OA. Los terminales por donde entra la señal se indican con los signos positivo y negativo. La salida se puede expresar como $v_O = av_d$ donde a representa la ganancia de lazo abierto del aparato, que usualmente es sumamente alta. La presencia de retro-alimentación negativa hace que el voltaje v_d sea muy pequeño, manteniendo así la salida por debajo de saturación y permitiendo el uso del OA en aplicaciones lineales.

Los terminales V_{CC} y V_{EE} deben ser conectados a los terminales positivo y negativo de la fuente de potencia. Estos terminales no siempre se muestran en el diagrama esquemático.

2. Basic Op Amp Circuits

Análisis ideal

Un análisis preliminar permite tratar al OA como un elemento ideal, para el cual:

- la ganancia de lazo abierto infinita, y consecuentemente la ganancia del lazo es $a\beta = \infty$ y la ganancia con retroalimentación es $A_f = 1/\beta$;
- la impedancia de entrada ∞ entre los terminales de entrada, en los cuales la corriente es cero;
- la retro-alimentación negativa hace que la diferencia de voltaje v_d sea cero, y se dice que los dos terminales están conectados virtualmente; si uno de ellos está conectado a tierra, el otro está conectado a *tierra virtual*;
- la resistencia de salida es cero.

Algunos ejemplos de circuitos útiles siguen a continuación.

Inverting amplifier

Since the op amp takes no input current, the same current flows through R_1 and R_2 . Because the non-inverting input is grounded, a *virtual ground* exist in the inverting input by virtue of the infinite gain and the negative feedback being used. Thus $v_i = i \times R_1$ and $v_o = -i \times R_2$. It follows that the gain of the inverting amplifier is $\frac{v_o}{v_i} = -\frac{R_2}{R_1}$.

The input impedance $R_i = R_1$. To find the output impedance, apply a test current source to the output and ground to v_i . Because of virtual ground, no current flows through R_1 . Since no current flows into the inverting input, the current through R_2 must be 0 as well. Thus, independently of the test current, v_o remains grounded in the ideal op amp. Consequently the output resistance is ideally 0.

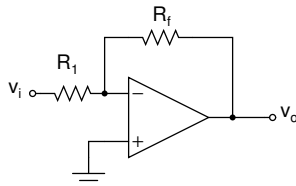

Summing amplifier

A KCL at the inverting input yields

$$\frac{v_1}{R_1} + \frac{v_2}{R_2} + \dots + \frac{v_n}{R_n} = -\frac{v_o}{R_f}$$

Thus

$$v_o = -\left(\frac{R_f}{R_1}v_1 + \frac{R_f}{R_2}v_2 + \dots + \frac{R_f}{R_n}v_n\right)$$

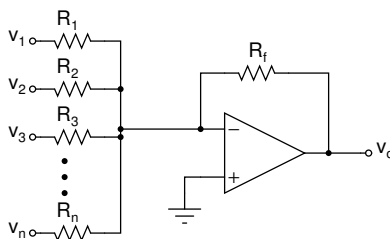

Non-inverting amplifier

Since the two terminals must be at the same voltage,

$$i_1 = \frac{-v_i}{R_1}$$

and

$$i_2 = \frac{-v_i - v_o}{R_2}$$

But no current flows into the inverting terminal, so $i_1 = i_2$. Substituting into this equation and solving for v_o yields

$$v_o = \left(1 + \frac{R_2}{R_1}\right) v_i$$

Input impedance R_i is infinite. Output impedance is very low.

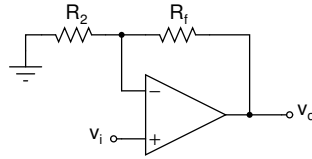

Voltage follower or *buffer* amplifier

Since $R_f = 0$ and this configuration is the same than the non-inverting amplifier, the gain is unity. The input impedance is, however, infinity. So this configuration eliminates loading, allowing a source with a relatively large Thevenin's resistance to be connected to a load with a relatively small resistance.

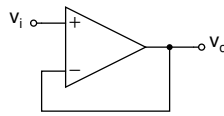

Difference amplifier

This circuit provides an output voltage that is proportional to the difference of the two inputs. Applying KCL at the inverting terminal yields

$$i_1 = \frac{v_1 - v_-}{R_1} = i_2 = \frac{v_- - v_o}{R_2}$$

Solving for v_o and reordering terms gives

$$v_o = \frac{R_1 + R_2}{R_1} v_- - \frac{R_2}{R_1} v_1$$

Since $v_- = v_+ = \frac{R_4}{R_3 + R_4} v_2$,

$$v_o = \frac{R_1 + R_2}{R_1} \frac{R_4}{R_3 + R_4} v_2 - \frac{R_2}{R_1} v_1$$

By choosing $R_1 = R_3$ and $R_2 = R_4$ one gets that

$$v_o = \frac{R_2}{R_1} (v_2 - v_1)$$

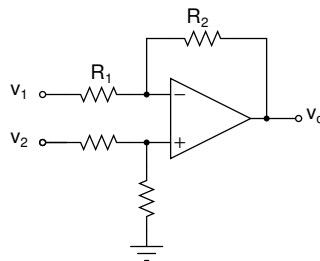

Current-to-voltage converter

Since the source current i_s can not flow into the amplifier's inverting input, it must flow through R_f . Since the inverting input is virtual ground,

$$v_o = -i_s R_f$$

Also, the virtual ground assumption implies that

$$R_i = 0$$

for this circuit.

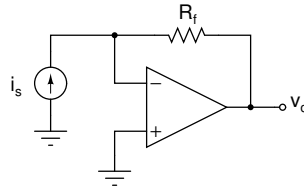

Voltage-to-current converter

In this circuit, the load is not grounded but takes the place of the feedback resistor. Since the inverting input is virtual ground,

$$i_L = i_{in} = \frac{v_{in}}{R_1}$$

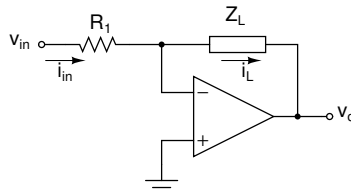

Instrumentation amplifier

This amplifier is just two buffers followed by a differential amplifier. So it is a differential amplifier but the two sources see an infinite resistance load.

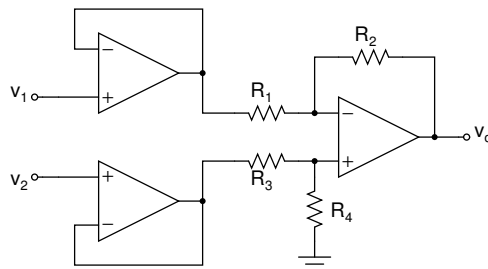

Integrator

Let v_{in} be an arbitrary function of time. The current through the capacitor is $i_C = \frac{v_C}{R_1}$. From the capacitor law,

$$i_C = C \frac{dv_C}{dt}$$

or

$$v_o = -v_C = -\frac{1}{C} \int i_C dt = -\frac{1}{R_1 C} \int v_{in} dt$$

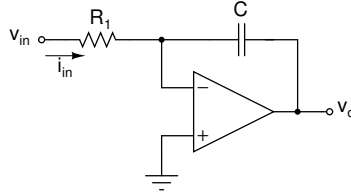

Active low-pass filter

Here we assume that the input is sinusoidal. Thus we can use the concepts of impedance and reactance and work in the frequency domain. Thus, the circuit is an inverting amplifier, but the feedback resistor as been replaced with Z_f , the parallel combination of R_2 and C . Therefore,

$$Z_f = \frac{\frac{1}{sC} R_2}{\frac{1}{sC} + R_2} = \frac{R_2}{1 + sCR_2}$$

From the expression for the inverting amplifier's gain,

$$v_o(s) = -\frac{Z_f}{R_1} = -\frac{R_2}{R_1} \frac{1}{1 + sCR_2} v_i(s)$$

which is small for s large.

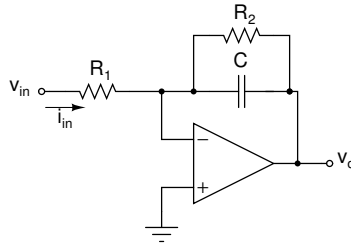

Differentiator

Here the input current is determined by the capacitor law,

$$i_{in} = C \frac{dv_{in}}{dt}$$

Thus

$$v_o = -R_f i_{in} = -R_f C \frac{dv_{in}}{dt}$$

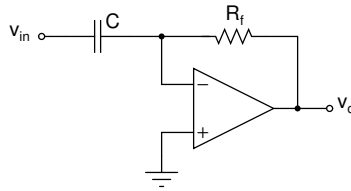

Active high-pass filter

Like in the low-pass filter, we consider v_{in} to be sinusoidal and apply impedance concepts. The configuration is again like the inverting amplifier, but the resistor R_1 as been replaced with Z_1 , which is R_1 in series with C . Thus

$$Z_1 = R_1 + \frac{1}{sC} = \frac{sR_1C + 1}{sC}$$

and

$$v_o = -\frac{R_f}{Z_1} = -\frac{sCR_f}{sR_1C + 1}$$

which is small for s small.

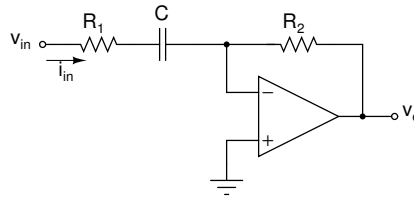

Logarithmic Amplifier

Here output and diode's voltage are equal in magnitude and of opposite signs. Since

$$i_D \approx I_S \exp\left(\frac{v_D}{V_T}\right)$$

where V_T is the thermal voltage, equal to $25mV$ at room temperature. It follows that

$$v_o = -v_D = -V_T (\log(v_{in}/R_1) - \log I_S)$$

and is thus proportional to the logarithm off the input.

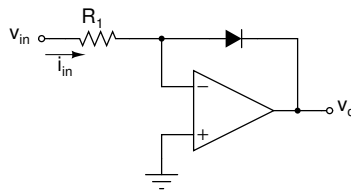

Anti-logarithmic Amplifier

The current i_{IN} is given by

$$i_D \approx I_S \exp\left(\frac{v_D}{V_T}\right)$$

or

$$i_{IN} \approx I_S \exp\left(\frac{v_{IN}}{V_T}\right)$$

Thus the output voltage is

$$v_O = -i_{IN}R_f \approx I_S R_f \exp\left(\frac{v_{IN}}{V_T}\right)$$

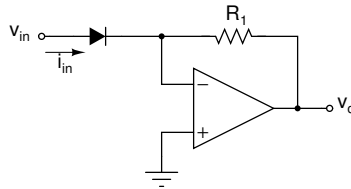

Comparator

An op amp can be used as a comparator in a circuit like the one shown below. This is a non-linear circuit in which the output saturates to about 90% of the positive and negative supply voltages. The polarity of the output voltage depends on the sign of the differential input, $v_i - v_{REF}$.

The sketch shows non-ideal characteristics typically found in op amps. The offset voltage, v_{OFFSET} , is on the order of few millivolts and causes the transition from low to high to be slightly displaced from the origin. v_{OFFSET} can be negative or positive, and is zero in an ideal op amp. The possibility of having voltages between plus and minus v_{SAT} , a consequence of the finite gain of practical op amps, is also shown. This part of the curve would be vertical if the op amp is ideal. Special integrated circuits (like the MC1530) are specially built to be used as comparators and minimize these non-ideal effects.

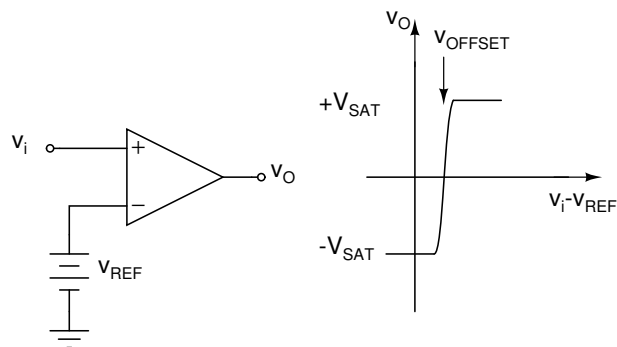

Square Wave Generator

This circuit is an oscillator that generates a square wave. It is also known as an *astable multivibrator*. The op amp works as a comparator. Let's assume that the op amp output goes high on power-on, thus making $v_O = +V_Z$. The capacitor charges with a time constant $\tau = RC$. When the capacitor voltage reaches $\beta v_O = \frac{R_3}{R_2 + R_3}$, the op amp output switches low, and $v_O = -V_Z$ as shown in the graph.

