

Computo de f_t y "slew rate" del uA741

Manuel Toledo
 ECE Department
 University of Puerto Rico
 Mayaguez, Puerto Rico
 8 de noviembre de 2012

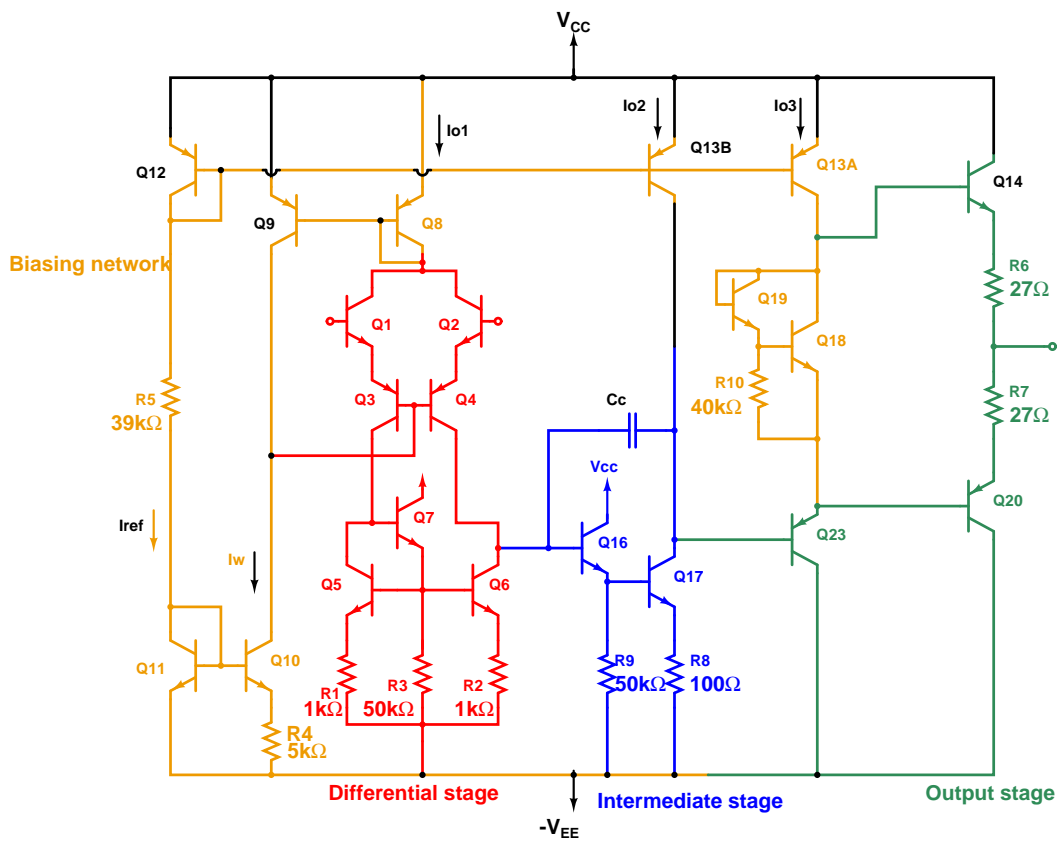

Overall gain

Etapa diferencial:

$$\begin{aligned}
 A_{v1} &= -G_{m1} (R_{o1} || R_{i2}) = \left(\frac{-1}{5.26} mA/V \right) (6.65M\Omega || 4M\Omega) \\
 &= -(0.19mA/V)(2.5M\Omega) = \boxed{-475V/V}
 \end{aligned}$$

Segunda etapa (intermedia):

$$\begin{aligned}
 A_{v2} &= \frac{v_{c17}}{v_{b16}} = \frac{v_{e16}}{v_{b16}} \frac{v_{c17}}{v_{e16}} \\
 &= (1) \left(-\frac{g_{m17} R_{o2}}{1 + g_{m17}(100\Omega)} \right) \\
 g_{m17} &= g_{m13B} = \frac{550\mu A}{25mV} = 22mA/V \\
 R_{o2} &= r_{o17} (1 + g_{m17}(100\Omega)) \parallel r_{o13B} \\
 r_{o17} &= \frac{125V}{0.55mA} = 227k\Omega & r_{o13B} &= \frac{50V}{0.55mA} = 90.9k\Omega \\
 R_{o2} &= 227k\Omega (1 + (22mA/V)(0.1k\Omega)) \parallel 90.9k\Omega = 80.8k\Omega \\
 A_{v2} &= -\frac{(22mA/V)(80.8k\Omega)}{1 + (22mA/V)(0.1k\Omega)} = \boxed{-555V/V}
 \end{aligned}$$

La ganancia de la tercera etapa (de salida) es 1 (etapa "push-pull" que trabaja como dos "emitter followers").

Overall gain:

$$A_v = (-475V/V)(-555V/V) = \boxed{263625V/V}$$

f_t y "slew-rate"

Aplicando el teorema de Miller al condensador de $30pF$,

$$C_{eq} = 30pF (1 - A_M) = 30pF (1 + 555) = 16680pF$$

Polo dominante, debido a C_{eq} :

$$f_p = \frac{1}{2\pi C_{eq}(R_{o1} \parallel R_{i2})} = \frac{1}{2\pi(16680pF)(2.5M\Omega)} = 3.82Hz$$

Frecuencia de ganancia unitaria es igual a f_p multiplicado por la ganancia:

$$f_t = 263625V/V \times 3.82Hz = \boxed{1MHz}$$

Slew-rate:

$$\begin{aligned}
 SR &= \left. \frac{dv_o}{dt} \right|_{max} = A_2 \times \left. \frac{dv_{b16}}{dt} \right|_{max} = 555 \frac{I_{C,Q8}}{C_{eq}} \\
 &= 555 \frac{19mA}{16680pF} = \boxed{0.63V/\mu s}
 \end{aligned}$$